

# Series Circuits

Two types of current are readily available to the consumer today. One is *direct current* (dc), in which ideally the flow of charge (current) does not change in magnitude (or direction) with time. The other is *sinusoidal alternating current* (ac), in which the flow of charge is continually changing in magnitude (and direction) with time.

The battery of Fig. below, by virtue of the potential difference between its terminals, has the ability to cause (or “pressure”) charge to flow through the simple circuit. The positive terminal attracts the electrons through the wire at the same rate at which electrons are supplied by the negative terminal. As long as the battery is connected in the circuit and maintains its terminal characteristics, the current (dc) through the circuit will not change in magnitude or direction.

Battery

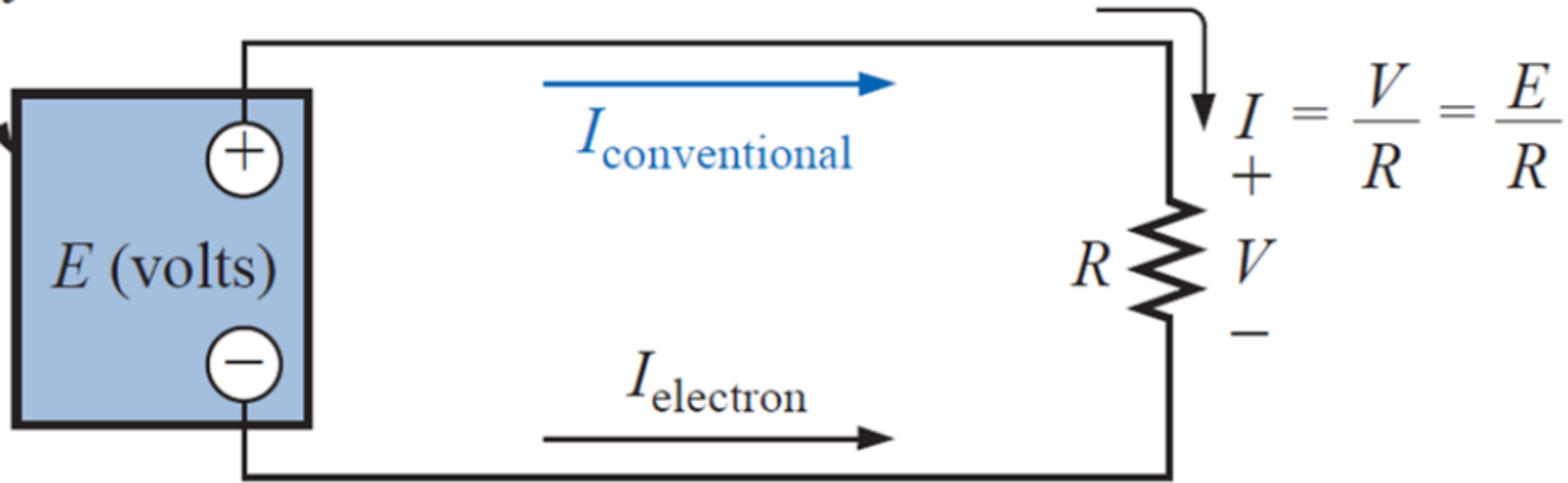

*Introducing the basic components of an electric circuit.*

The SERIES CIRCUIT consists of any number of elements joined at terminal points, providing at least one closed path through which charge can flow. The circuit of Fig. 5.4(a) has three elements joined at three terminal points (a, b, and c) to provide a closed path for the current  $I$ .

*Two elements are in series if*

- 1. They have only one terminal in common (i.e., one lead of one is connected to only one lead of the other).*
- 2. The common point between the two elements is not connected to another current-carrying element.*

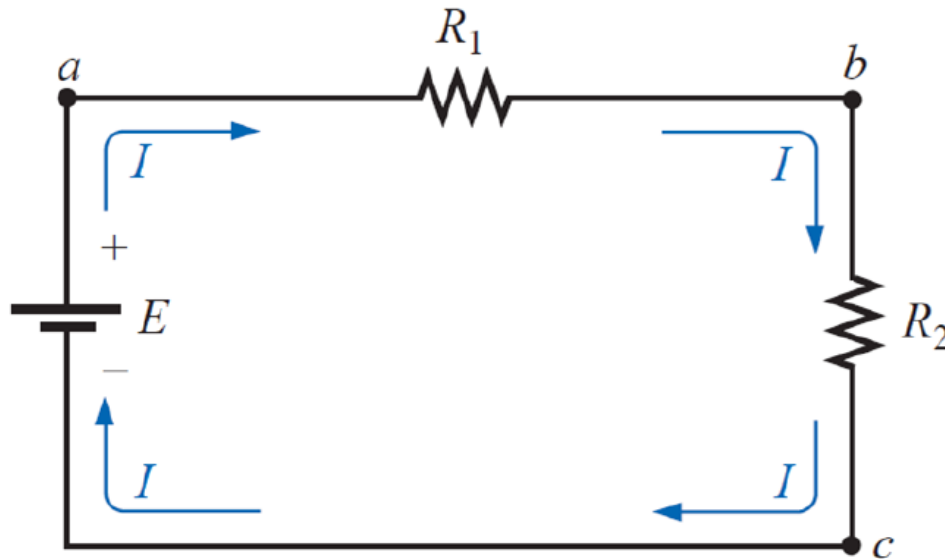

## In series circuits

The total resistance of a series circuit is the sum of the resistance levels.  
The current is the same through each element.

$$R_T = R_1 + R_2 + \dots + R_N$$
$$I_S = I_1 = I_2 = \dots = I_N$$

using Ohm's law; that is,

$$V_1 = IR_1, V_2 = IR_2, V_3 = IR_3, \dots, V_N = IR_N$$

The power delivered to each resistor can be calculated as

$$P_1 = IV_1 = \frac{V_1}{R_1} V_1 = \frac{V_1^2}{R_1} = I^2 R_1$$

The total power delivered to a resistive circuit is equal to the total power dissipated by the resistive elements.

$$P_{del} = P_1 + P_2 + \dots + P_N$$

### EXAMPLE 1

- Find the total resistance for the series circuit.
- Calculate the source current  $I_s$ .
- Determine the voltages  $V_1$ ,  $V_2$ , and  $V_3$ .
- Calculate the power dissipated by  $R_1$ ,  $R_2$ , and  $R_3$ .
- Determine the power delivered by the source, and compare it to the sum of the power levels of part (d).

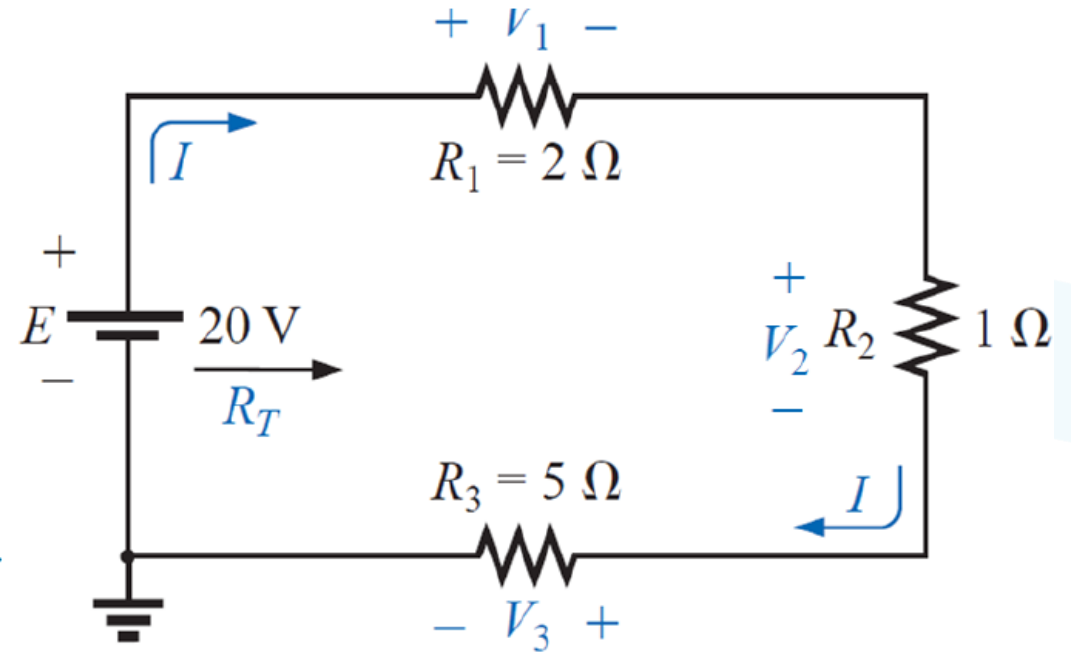

### EXAMPLE 2

Determine  $R_T$ ,  $I$ , and  $V_2$  for the following circuit

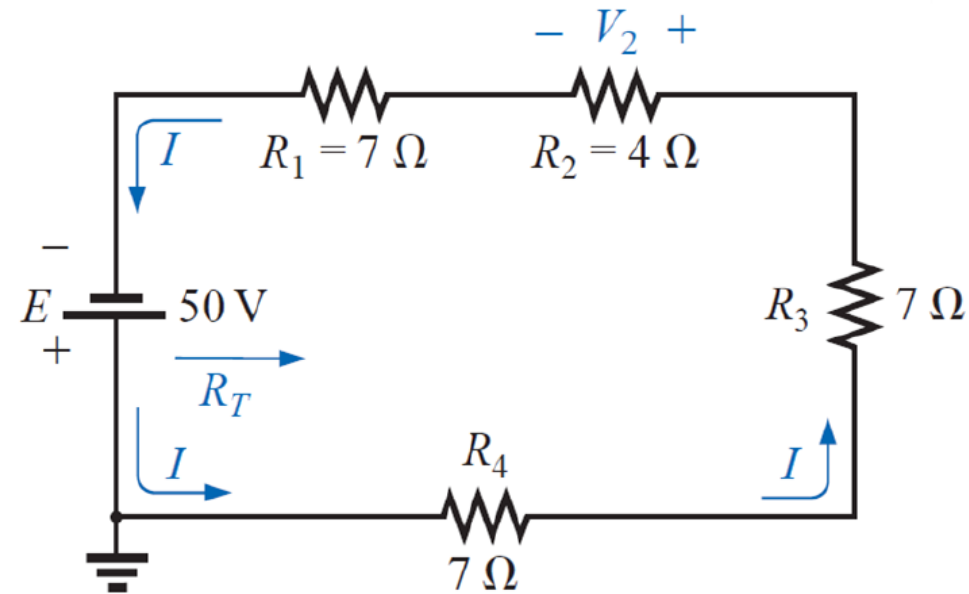

### Electromotive Force (EMF)

$$E = V + Ir$$

$$V = E - Ir$$

$$E = IR + Ir = I(r + R)$$

### EXAMPLE 3

Calculate the EMF of the cell in figure shown below

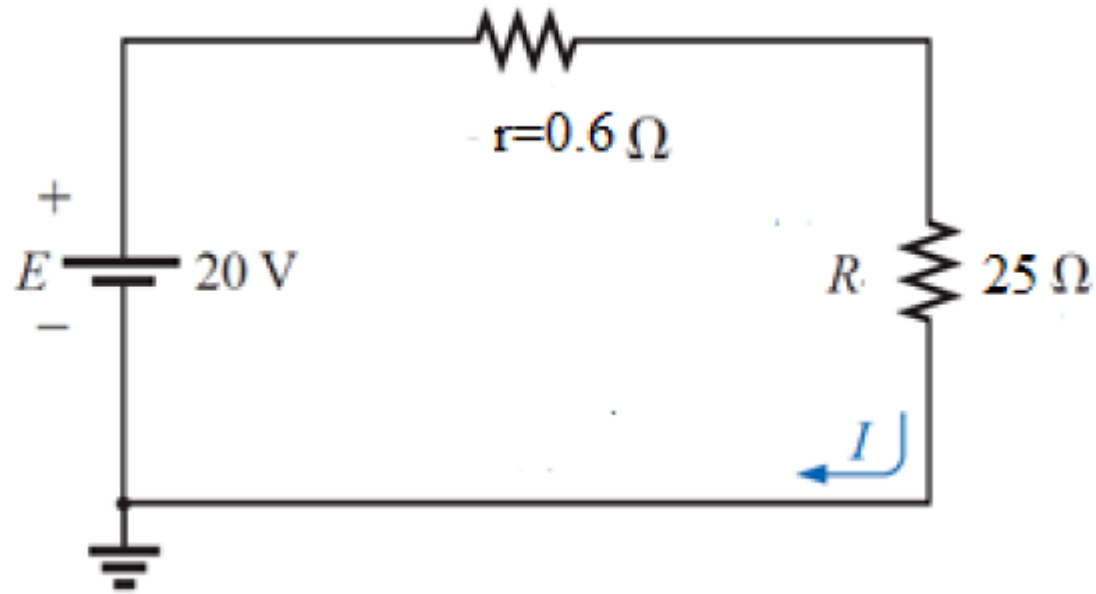

## VOLTAGE SOURCES IN SERIES

Voltage sources can be connected in series, , to increase or decrease the total voltage applied to a system.

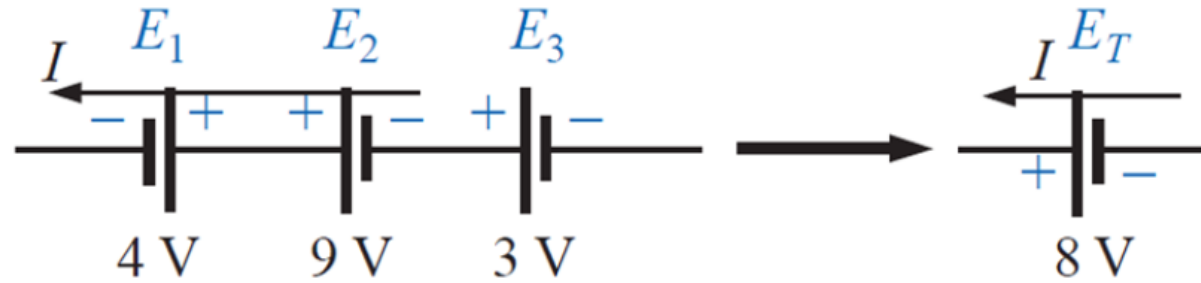



## KIRCHHOFF'S VOLTAGE LAW

**Kirchhoff's voltage law (KVL) states that the algebraic sum of the potential rises and drops around a closed loop (or path) is zero.**

A **closed loop** is any continuous path that leaves a point in one direction and returns to that same point from another direction without leaving the circuit.

$$\sum_{\text{loop}} V = 0$$

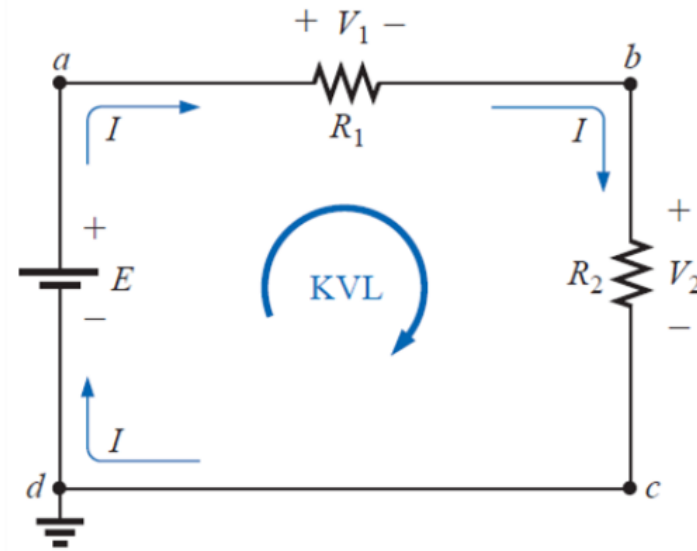

Kirchhoff's voltage law can also be stated in the following form:

$$\sum_{\curvearrowright} V_{\text{rises}} = \sum_{\curvearrowright} V_{\text{drops}}$$

### EXAMPLE 4

Determine the unknown voltages for the networks of following Figures

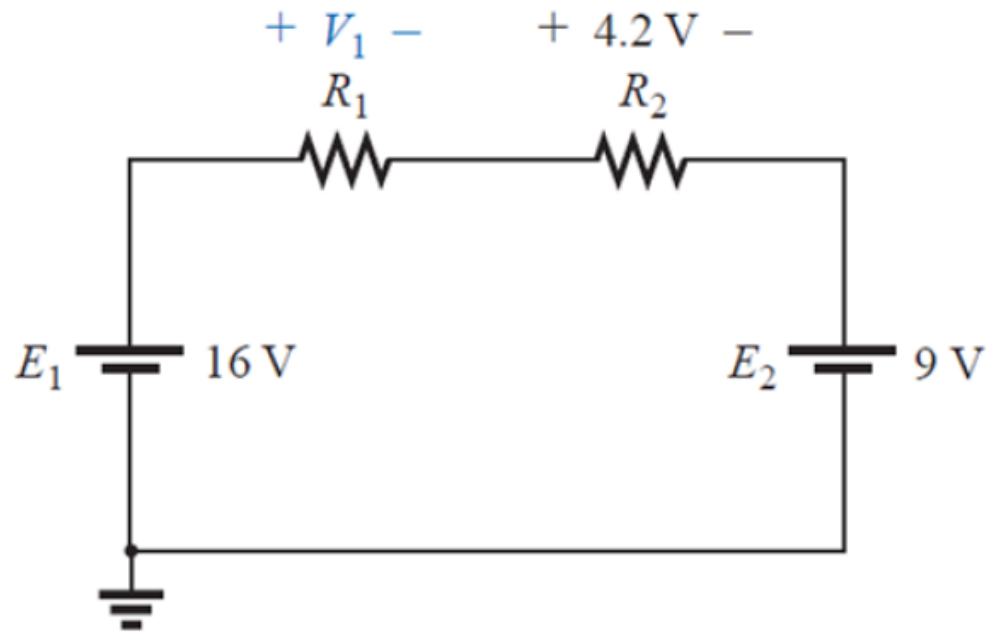

(a)

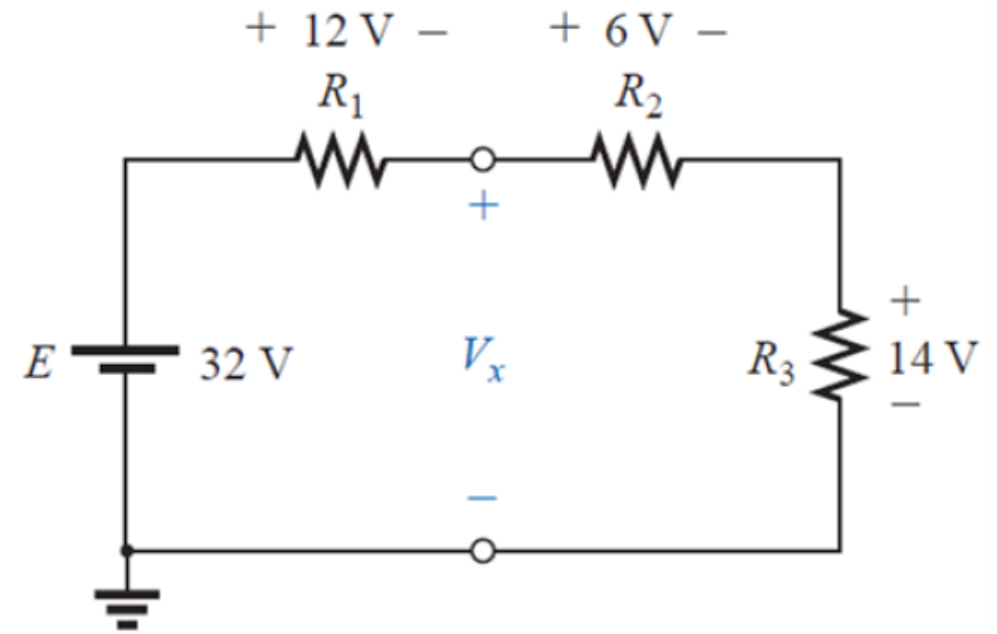

(b)

### EXAMPLE 5

Determine  $I$  and the voltage across the  $7\text{-}\Omega$  resistor for the network of the Figure shown below.

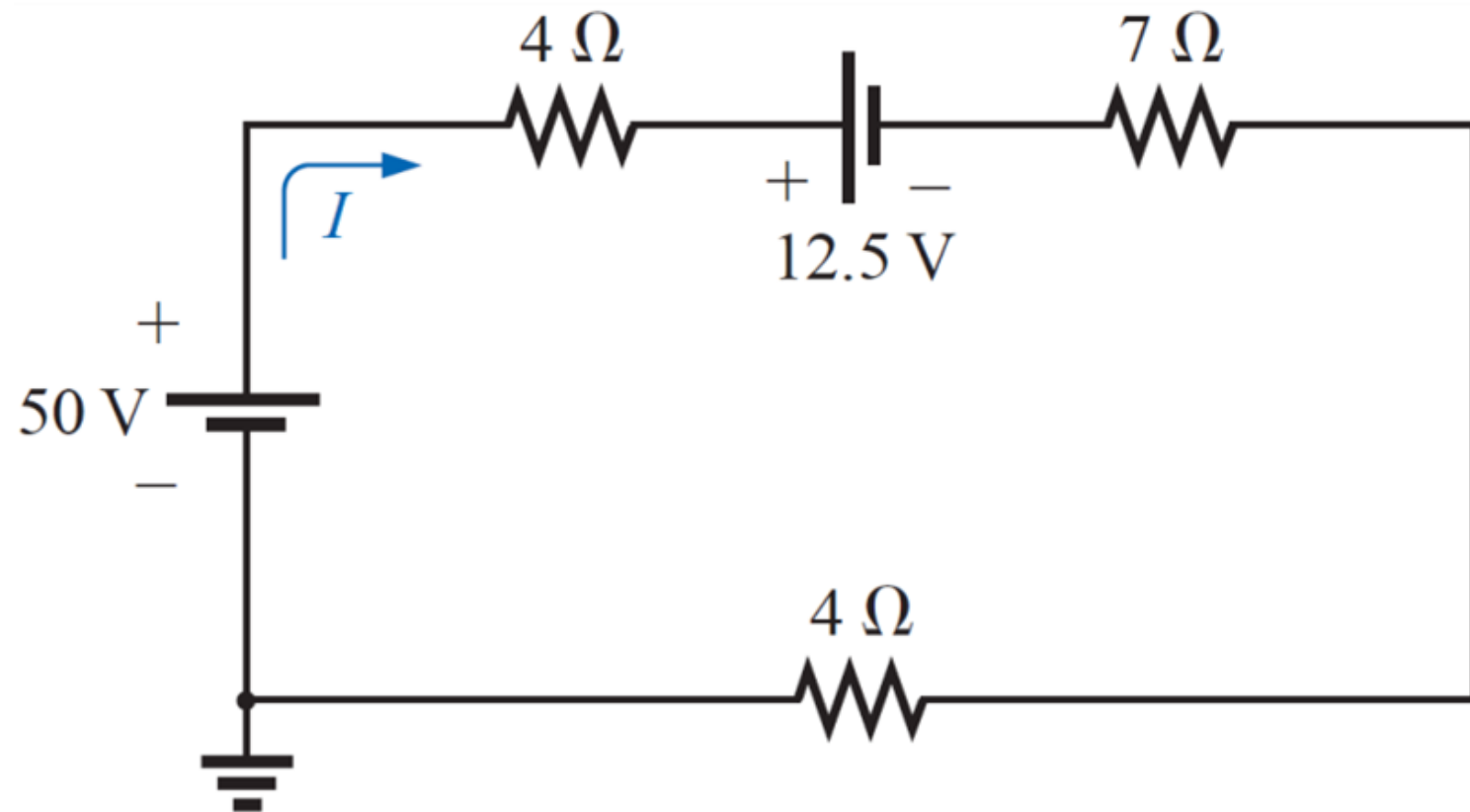



## VOLTAGE DIVIDER RULE

In a series circuit,

*the voltage across the resistive elements will divide as the magnitude of the resistance levels.*

$$R_T = R_1 + R_2$$

$$I = \frac{E}{R_T}$$

Applying Ohm's law:

$$V_1 = IR_1 = \frac{E}{R_T} R_1 = E \frac{R_1}{R_T}$$

$$V_2 = IR_2 = \frac{E}{R_T} R_2 = E \frac{R_2}{R_T}$$

In general

$$V_x = E \frac{R_x}{R_T}$$

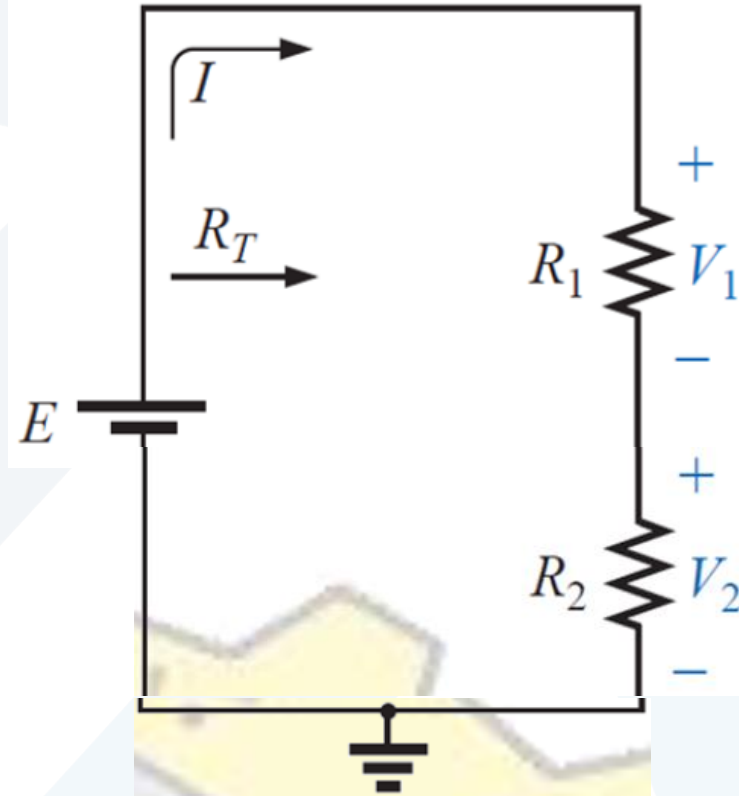

In words, the **voltage divider rule** states that

*The voltage across a resistor in a series circuit is equal to the value of that resistor times the total impressed voltage across the series elements divided by the total resistance of the series elements.*

### EXAMPLE 6

Using the voltage divider rule, determine the voltages  $V_1$  and  $V_3$  for the series circuit shown below

