

# Support Reactions in Planar Structural Systems

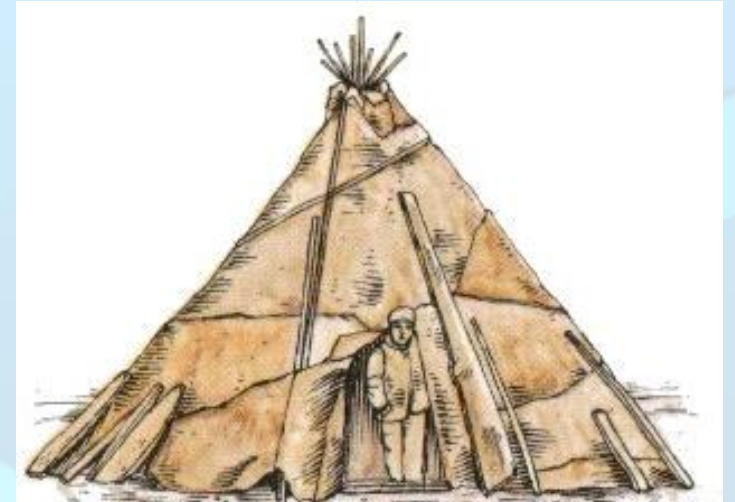

ردود أفعال المساند  
في الهياكل الحاملة  
(الجمال الإنشائية) المستوية

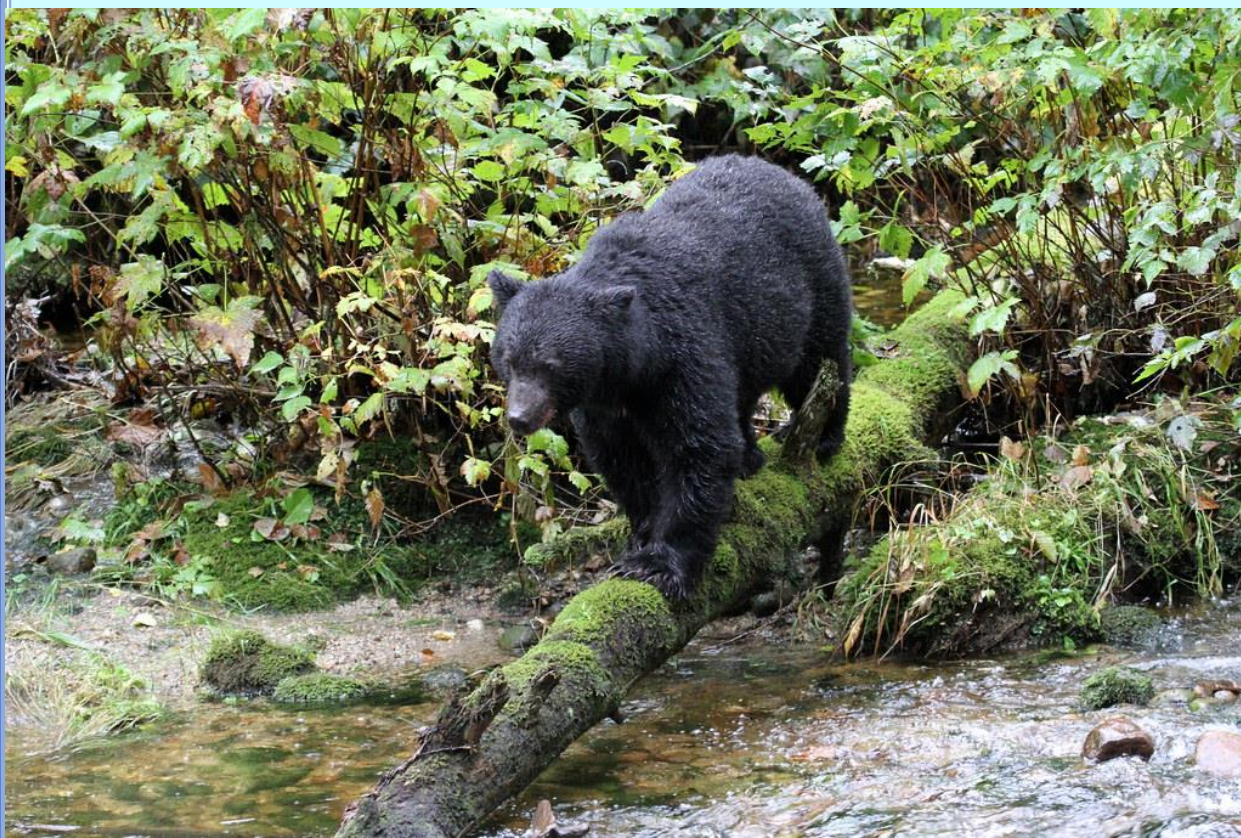





# Support Reactions ردود الأفعال في مساند الهياكل الحاملة المستوية

## 1. Plane Structures الهياكل الحاملة المستوية

### 1.1 Supports المساند

### 1.2 Statical Determinacy التقرير السكوني

### 1.3 Determination of the Support Reactions حساب ردود الأفعال في المساند

## Objectives:

In this chapter, the most common kinds of supports of simple structures and the different connecting elements of structures are introduced. We will discuss their characteristic features and how they can be classified, so that the students will be able to decide whether or not a structure is statically and kinematically determinate. Students will also learn from this chapter how the reactions (forces and couple moments) appearing at the supports and the connecting elements of a loaded structure can be determined. Here, the most important steps are the sketch of the free-body diagram and the correct application of the equilibrium conditions.

أنماط المساند. درجات الحرية والتقييد: الجمل الإنشائية المقررة سكونيا وكينماتيكيا. ردود الأفعال. مخطط الجسم الحر.

# 1. Plane Structures

## الإنشاءات المستوية

### 1.1 Supports

Geometrical Classification of Structures and Structural Elements:

التصنيف الجيومتري

Slender structural elements (cross-sectional dimensions much smaller than its length) that are loaded solely in their axial direction (tension or compression) are called *bars* or *rods*

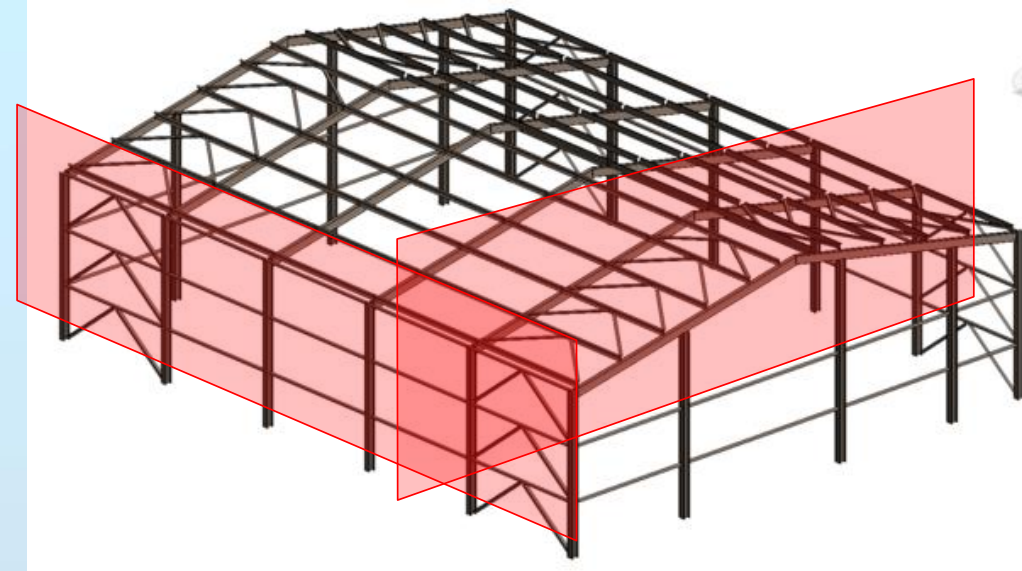
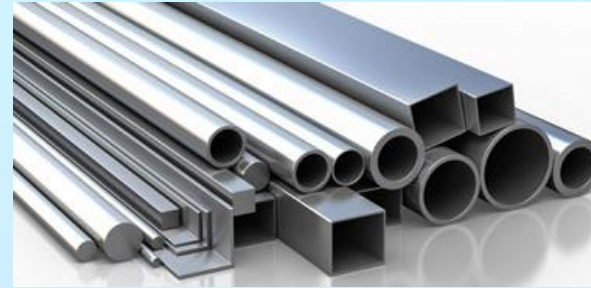

If these Elements are subjected to a load perpendicular to its axis, they are called *beams*.

إذا كانت الحمولات (القوى المؤثرة) على هذه العناصر متعامدة مع محاورها الطولية، دعيت هذه العناصر بالجيزان ومفردها جائز.

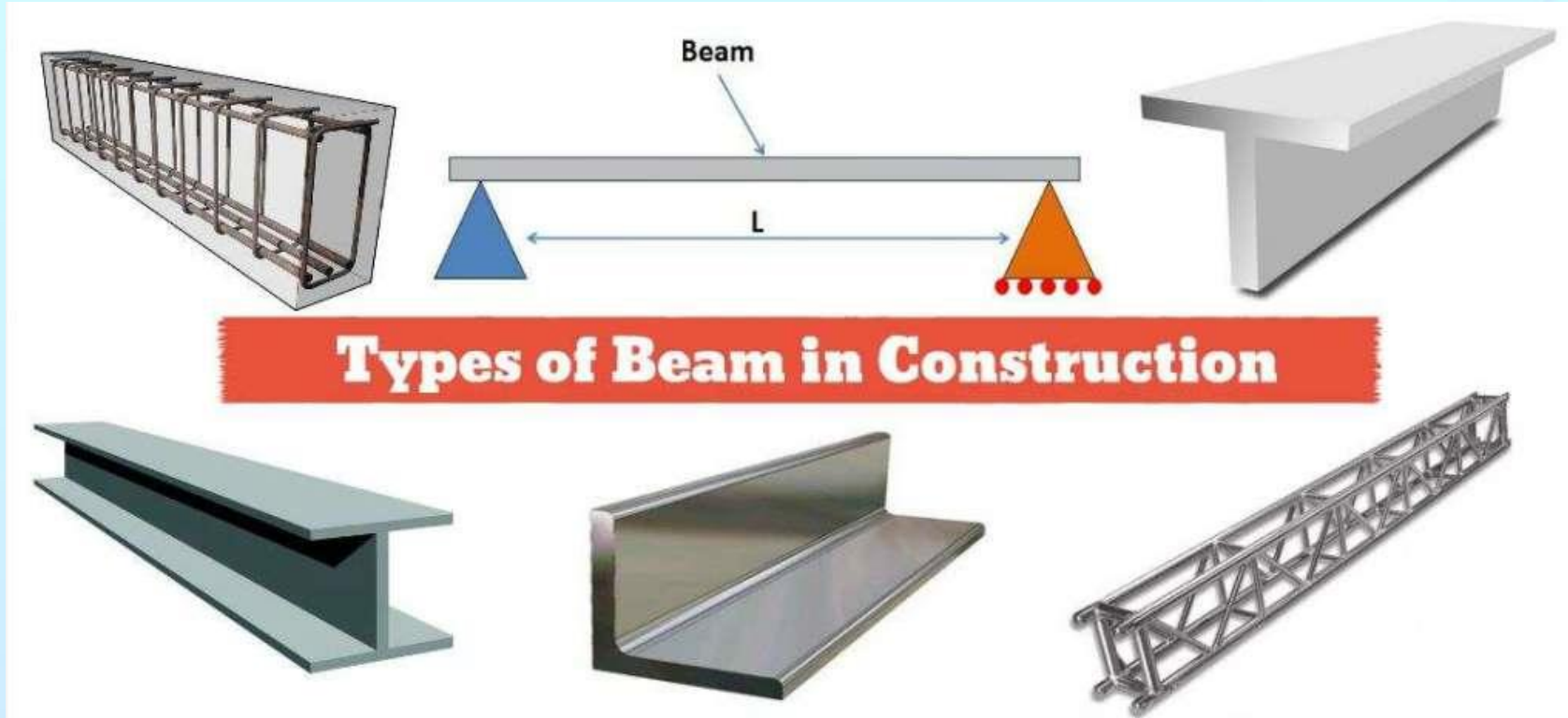

A curved beam is usually designated as an *arch*.

ويدعى الجائز المنحني قوساً وجمعها أقواس



Structures consisting of orthogonal or inclined, rigidly joined beams are called frames الإطارات



A plane structural element with a thickness much smaller than its characteristic inplane length is called *disk, panel* (shear wall) if it is solely loaded by in-plane forces.

الشرائح، الألواح أو في الأبنية جدران القص

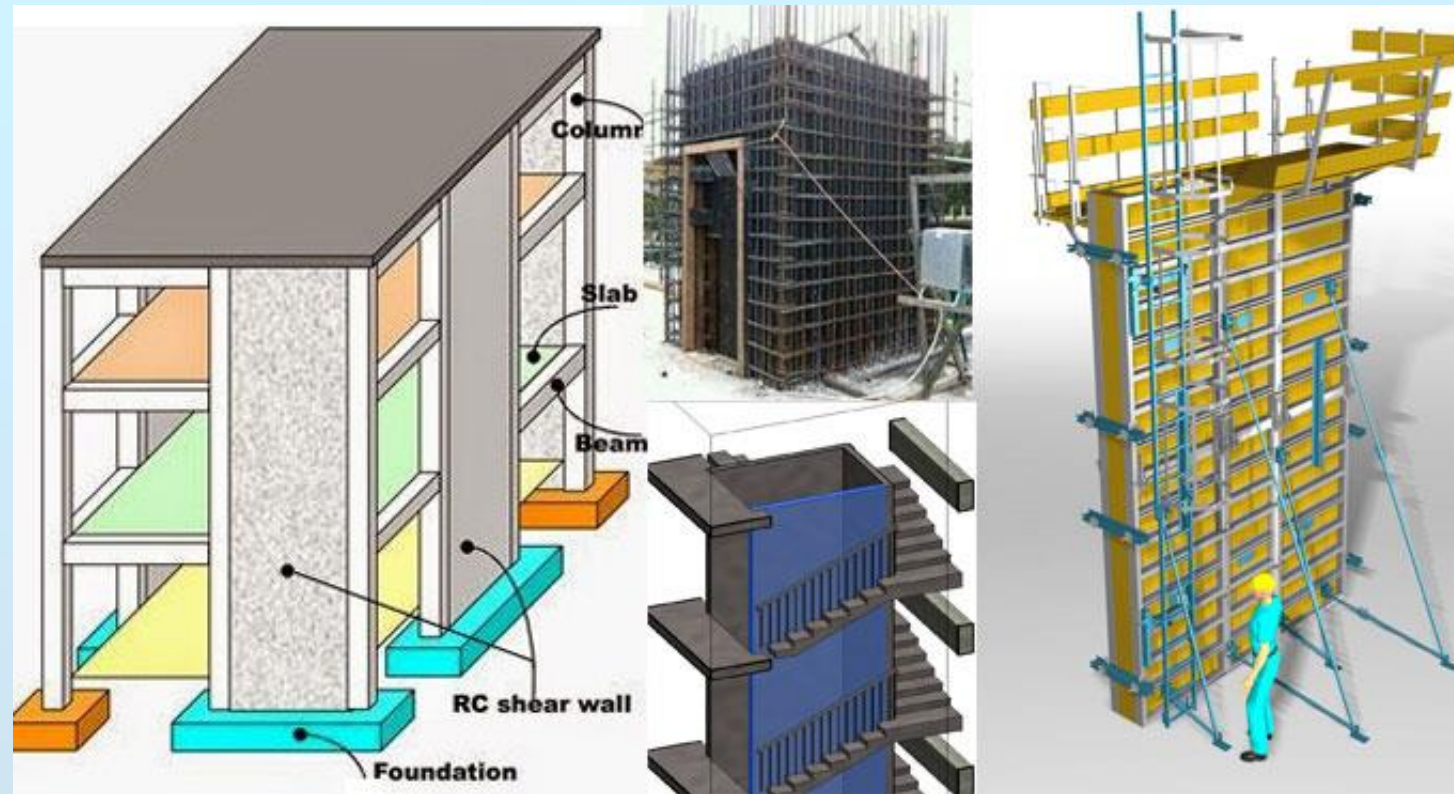



If the same geometrical structural Element is loaded perpendicularly to its midplane it is called a *plate* بلاطة . If such a structure is curved it is a *shell* قشرية .

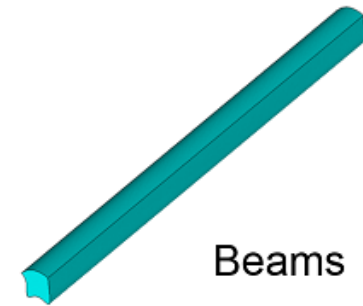
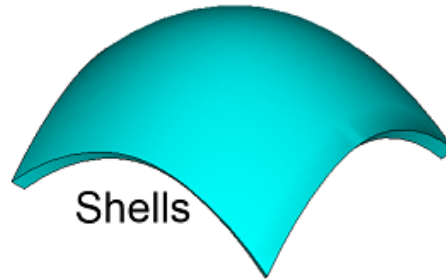
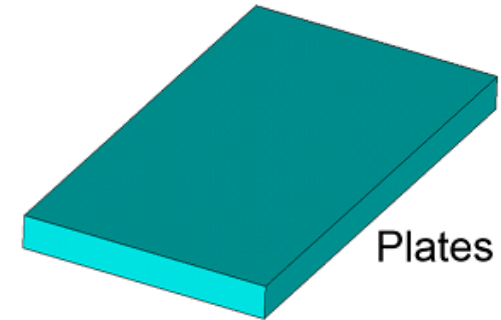
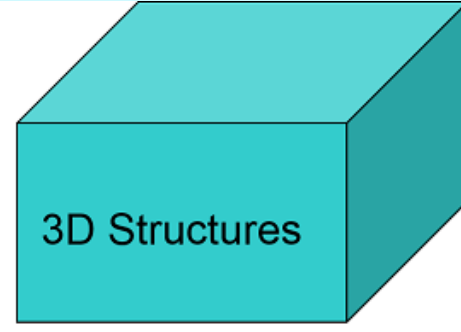

Structures are connected to their surroundings by *supports* whose purpose is to fix the structure in space in a specific position. *Supports* act against mortice forces.

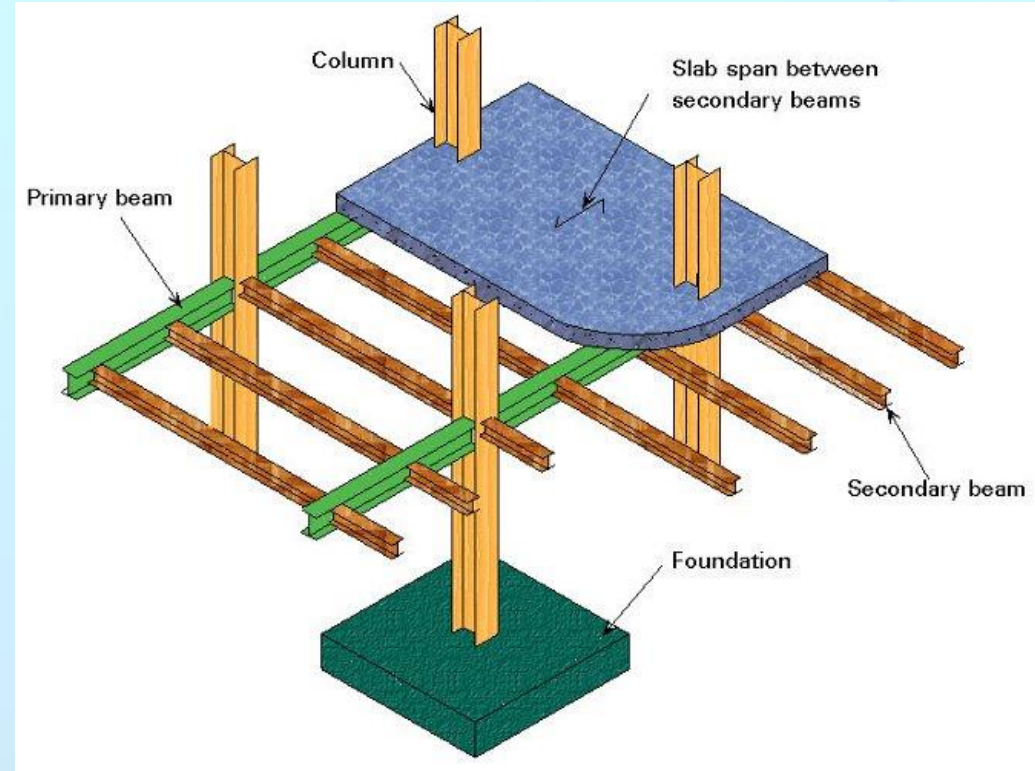

As an idealized example, consider the “roof” in figure a, loaded by external forces  $F_i$ , joined at  $A$  to a vertical wall by a pin, and supported at  $B$  by the strut  $S$ . Forces are transmitted to the wall and the ground via the supports  $A$  and  $B$ . According to the law of action and reaction (action = reaction) the same forces are exerted in opposite directions from the wall and the ground onto the roof. These forces from the environment onto the structure are reaction forces, and are termed support reactions.

They become visible in the free-body diagram (Figure b), where they are generally denoted by the same symbols as the supports, i.e. by  $A$  and  $B$  in this example.

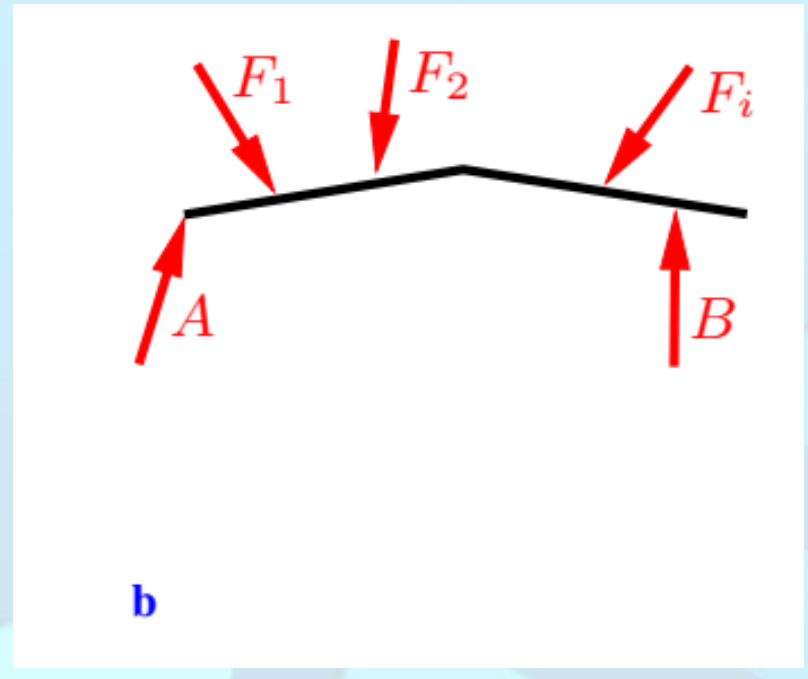
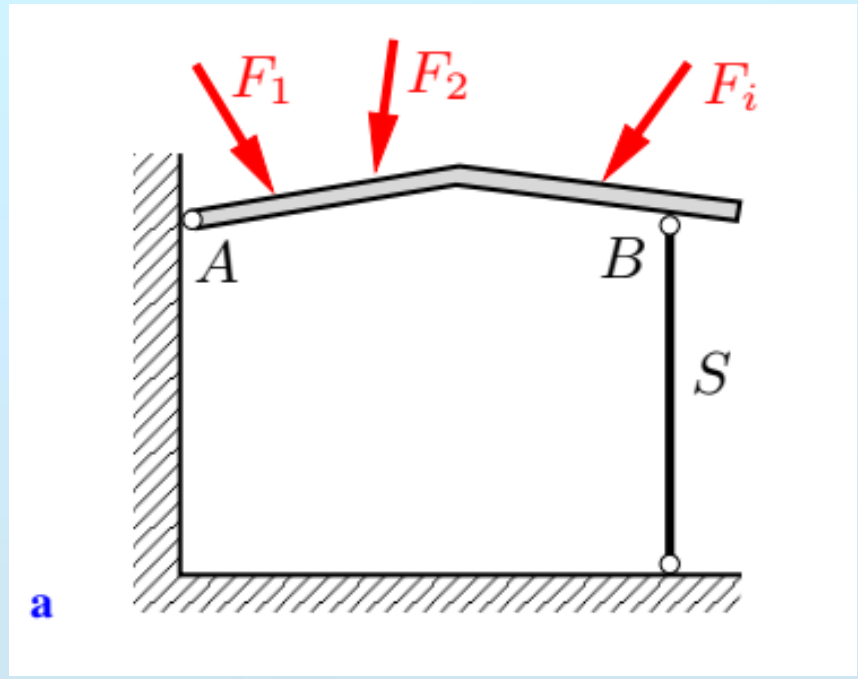

## Degrees of Freedom and Support Restraints

A free body in a plane with no restraints has **three** degrees of freedom.

It can be independently displaced by two translations in different directions and by one rotation about an axis perpendicular to the plane.

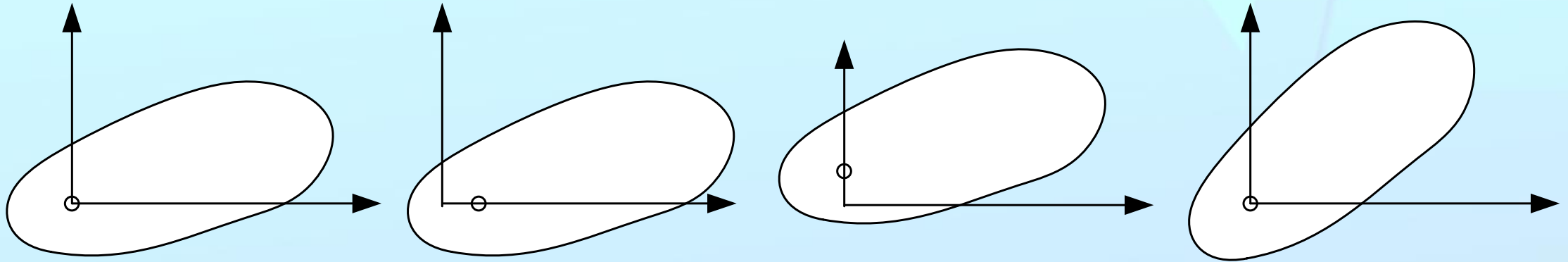

Supports (restraints) reduce the feasible displacements: each support reaction imposes a constraint. Let  $r$  be the number of support reactions. Then the number  $f$  of degrees of freedom of a body in a plane is given by:  $f = 3 - r$ .

وهي درجة الحرية لشريحة أو هيكل حامل مستوي.

We will now consider different types of supports and classify them by the number of support reactions involved.

Supports that can transmit only one single reaction ( $r = 1$ ). Examples of this type of support are the roller support without friction, the simple support and the support by a strut.

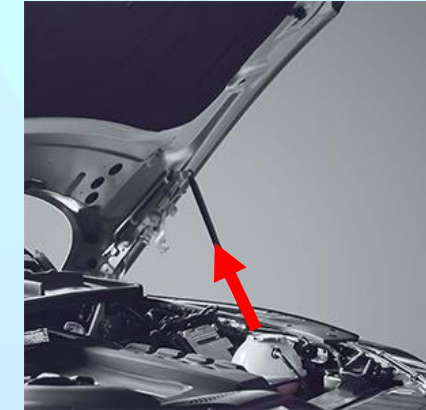

In this case, the direction of the reaction force is known, and its magnitude is unknown.

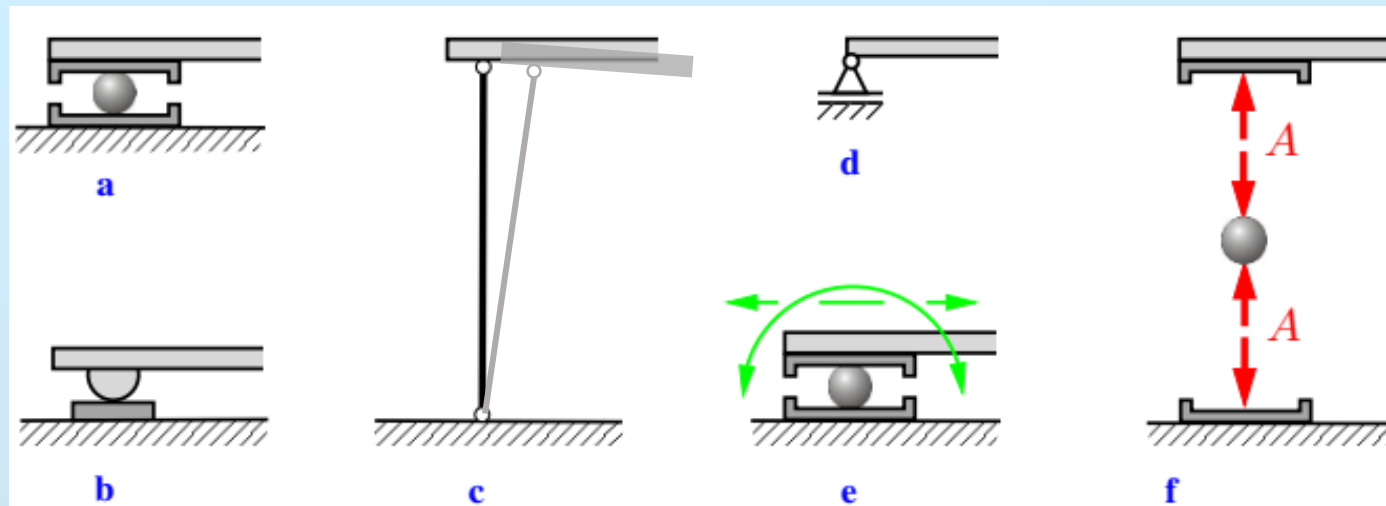

Supports that can transmit two reactions ( $r = 2$ ). Examples of this type of support are the hinged support.



and the support by two struts which are depicted symbolically in figure c.

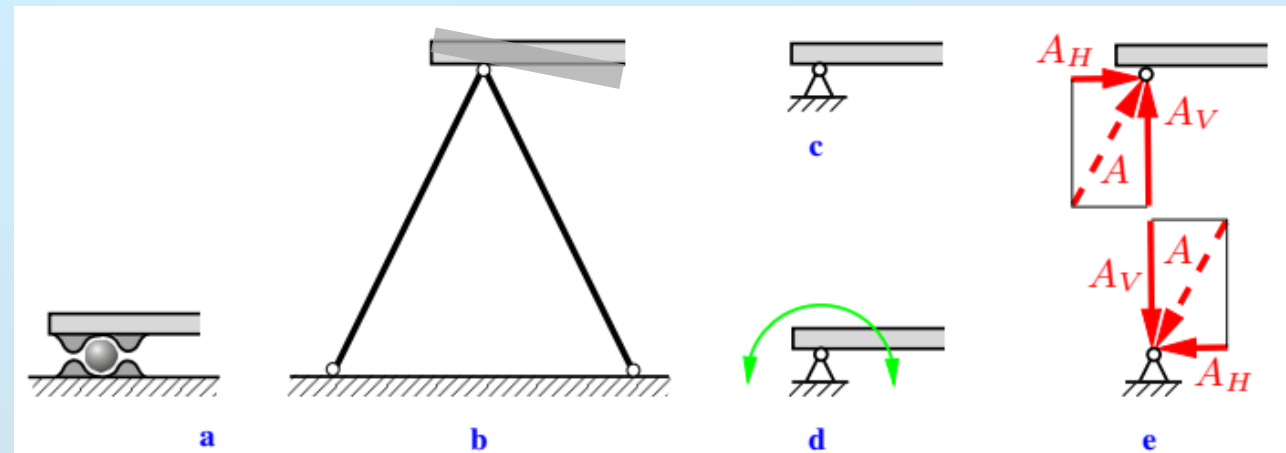

The rotational degree of freedom disappears if a support by two struts is complemented by an additional, somewhat shifted, third strut **figure a**.

The structure becomes immobile. In addition to the two force components, the support can now also transmit a couple moment, i.e., in total **three reactions**:  $r = 3$ .

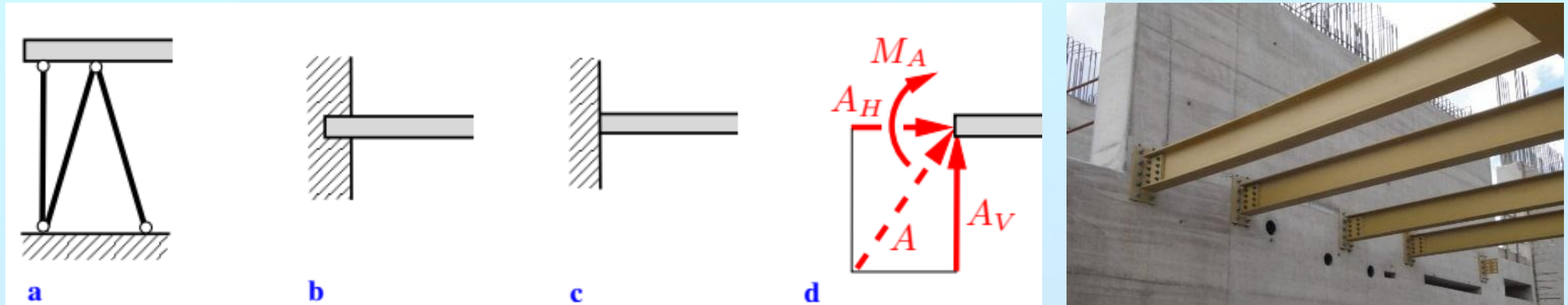

The same situation appears in the case of a clamped support (fixed support) according to **figure b** which symbolically is depicted in **figure c**. The free-body diagram in **figure d** shows that the clamped support can transmit a reaction force  $A$  of arbitrary magnitude & direction (or  $A_H$  and  $A_V$ ) and a couple moment  $M_A$  (or  $A_M$ ).

## 1.2 Static Determinacy

A structure is called **statically determinate** if the support reactions can be calculated from the equilibrium conditions.

Hence, a rigid body under the action of a general system of coplanar forces is in equilibrium if the following equilibrium conditions are satisfied:

$$\sum F_{ix} = 0, \quad \sum F_{iy} = 0, \quad \sum M_{i/O} = 0.$$

The axes and/or the pivotal point are arbitrary

$$\sum F_{ix'} = 0, \quad \sum F_{iy'} = 0, \quad \sum M_{i/O'} = 0.$$

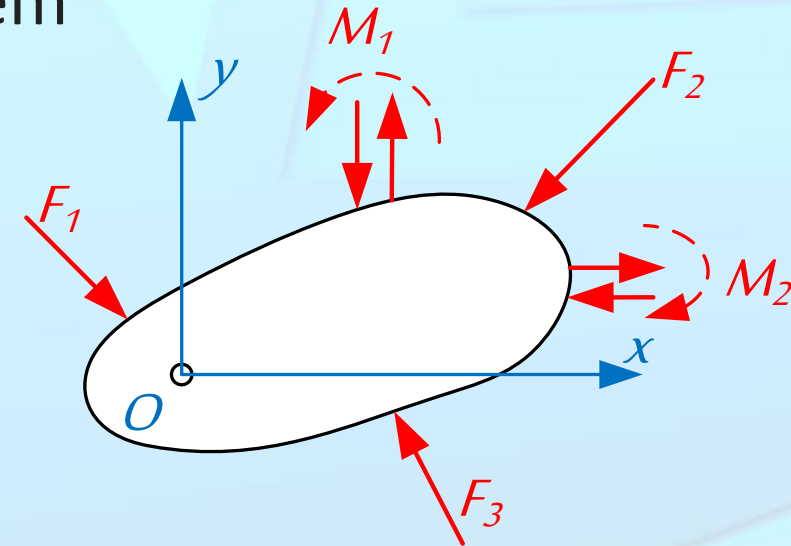

Since the number of unknowns must coincide with the number of equations, three unknown reactions (forces or couple moments) must exist at the supports:  **$r = 3$** . *It will be explained later that this necessary condition may not be sufficient for the determination of the support reactions.*



The beam in **figure a** is supported by the hinged support  $A$  and the simple support  $B$ . Accordingly, the three unknown support reactions  $A_H$ ,  $A_V$  &  $B$  exist. Therefore, with  $r = 3$  it follows from (5.1) that the beam is immobile:  $f = 3 - r = 0$ ; it is statically determinate.



The support reactions of the clamped beam in **figure b** consist of the two force components  $A_H$ ,  $A_V$  & the couple moment  $M_A$  (or  $A_M$ ).

Figure c shows a panel supported by the three struts A, B & C, each transmitting one reaction. In both cases, with  $r = 3$  and  $f = 0$ , the panel is statically determinate.

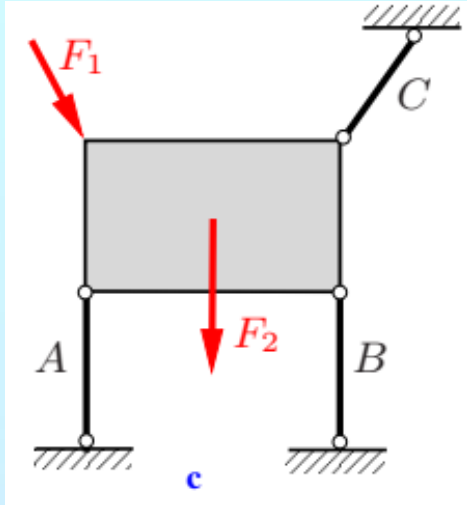

statically determinate

مقرر ستاتيکيا

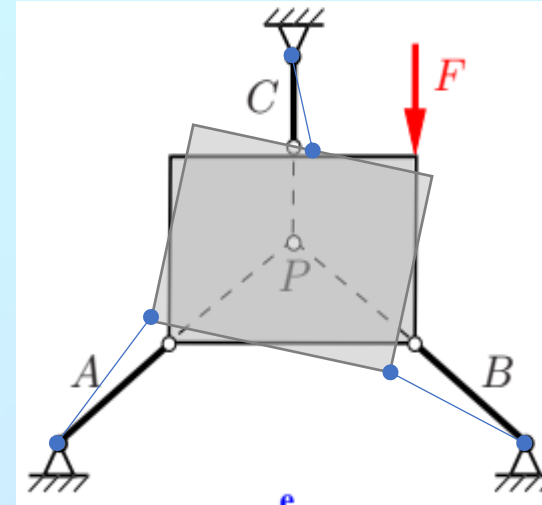
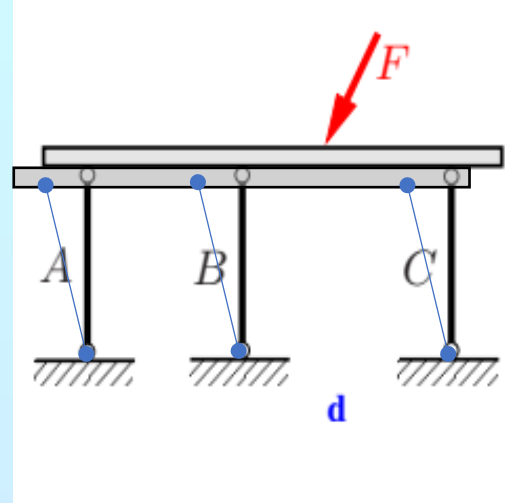

Kinematically indeterminate

غير مقرر کينماتيکيا

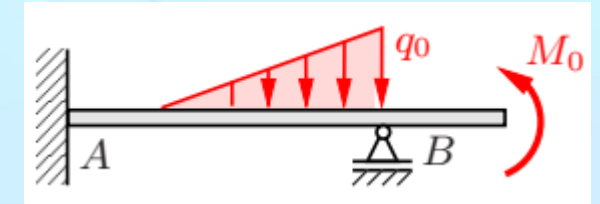

statically indeterminate

غير مقرر ستاتيکيا

## 1.3 Determination of the Support Reactions

In order to determine the support reactions, the method of free body diagram is applied: the body is freed from its supports and their action on the body is replaced by the unknown reactions.

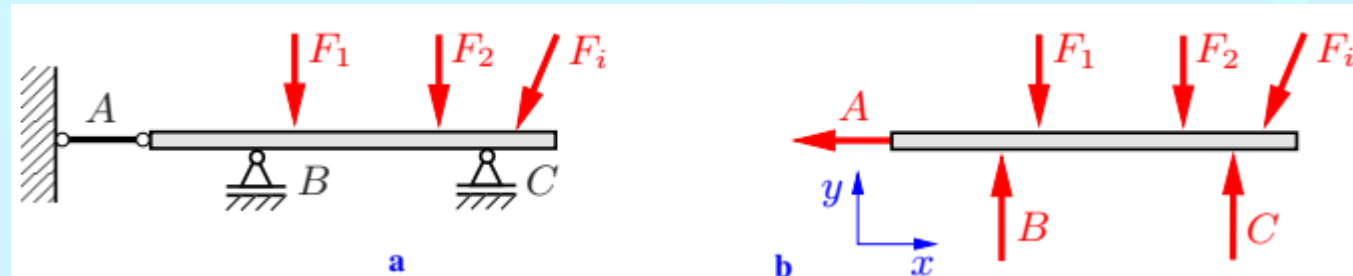

$$\sum F_{ix} = 0, \quad \sum F_{iy} = 0, \quad \sum M_{i/O} = 0.$$

**Example 1** The beam shown in **figure a** is loaded by the force  $F$  which acts under an angle  $\alpha$ . Determine the reaction forces at the supports  $A$  and  $B$ .

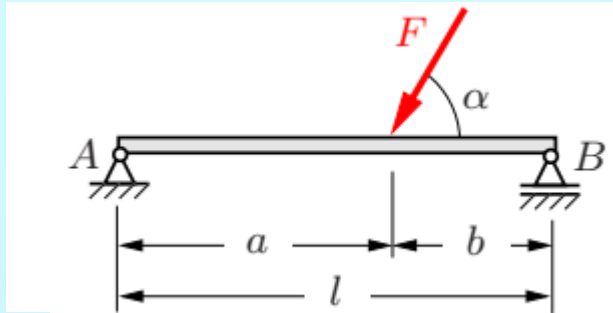

**Solution:** The beam is rigidly supported; the support  $A$  transmits two reactions and support  $B$  one reaction. In total, the three unknown reaction forces  $A_H$ ,  $A_V$  &  $B$  exist, therefore, the beam is statically determinate.

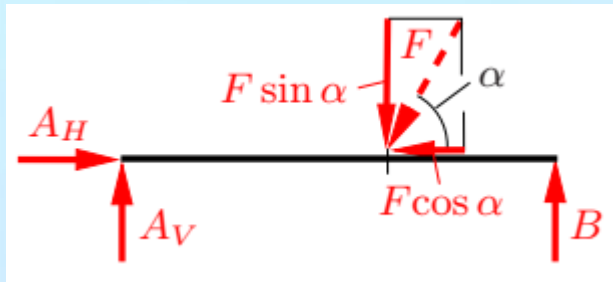

We free the beam from its supports and make the reaction forces visible in the free-body diagram where we choose their senses of direction along the action lines freely. Hence, the equilibrium conditions are given by

$$\sum F_{ix} = 0, \quad \sum F_{iy} = 0, \quad \sum M_{i/O} = 0.$$

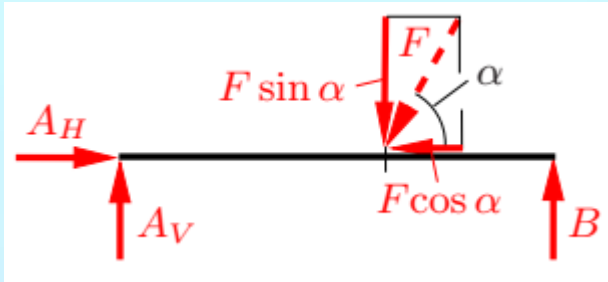
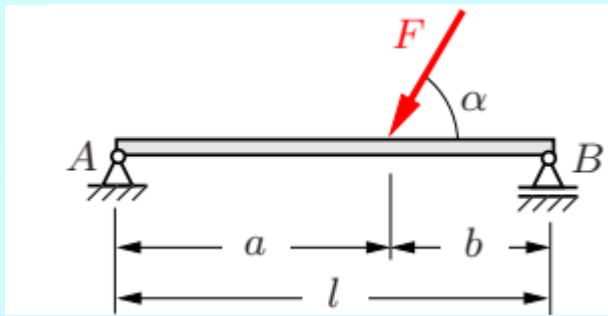

$$\sum F_{ix} = 0, \quad \sum F_{iy} = 0, \quad \sum M_{i/O} = 0.$$

$$\sum F_{ix} = 0: \quad A_H - F \cos \alpha = 0, \quad (1)$$

$$\uparrow \sum F_{iy} = 0: \quad A_V + B - F \sin \alpha = 0, \quad (2)$$

$$\downarrow \uparrow \sum M_{i/A} = 0: \quad lB - aF \sin \alpha = 0, \quad (3)$$

$$\text{Solving (1)} \Rightarrow A_H = F \cos \alpha$$

$$\text{Solving (3)} \Rightarrow B = (a/l)F \sin \alpha$$

$$\text{Sub. in (2)} \Rightarrow A_V = (b/l)F \sin \alpha$$

**Example 2** The clamped beam shown in **figure a** is loaded by the two forces  $F_1$  and  $F_2$ .

Determine the reactions at the support.

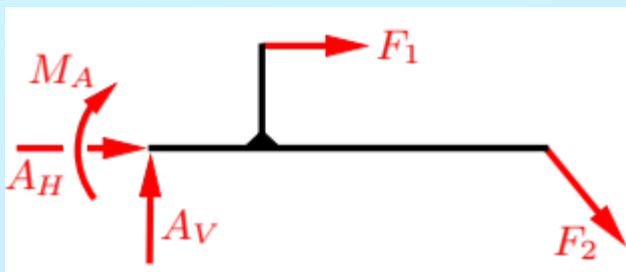
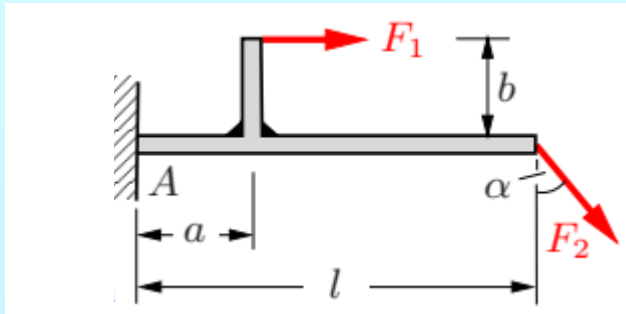

**Solution:**

We free the beam from its supports and make the reaction forces visible in the free-body diagram where we choose their senses of direction along the action lines freely.

Hence, the equilibrium conditions are given by

$$\sum F_{ix} = 0, \quad \sum F_{iy} = 0, \quad \sum M_{i/O} = 0.$$

$$\sum F_{ix} = 0: \quad A_H + F_1 + F_2 \sin \alpha = 0 \Rightarrow A_H = -(F_1 + F_2 \sin \alpha)$$

$$\uparrow \sum F_{iy} = 0: \quad A_V - F_2 \cos \alpha = 0 \Rightarrow A_V = F_2 \cos \alpha$$

$$\downarrow \uparrow \sum M_{i/A} = 0: \quad -M_A - bF_1 - lF_2 \cos \alpha = 0 \Rightarrow M_A = -(bF_1 + lF_2 \cos \alpha)$$

**Example 3.** Determine the support reactions for the depicted system.  
Given:  $F_1 = 2$  kN,  $F_2 = 3$  kN,  $a = 1$  m,  $M_0 = 4$  kNm,  $q_0 = 5$  kN/m,  $\alpha = 45^\circ$ .

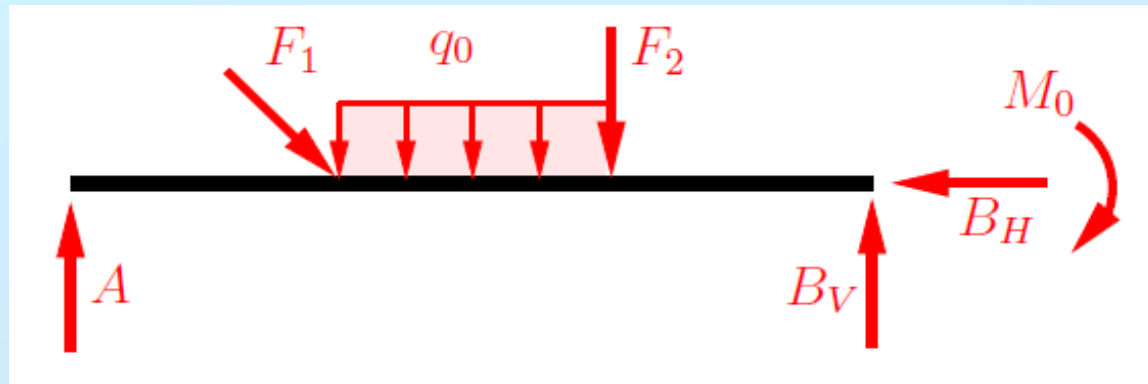
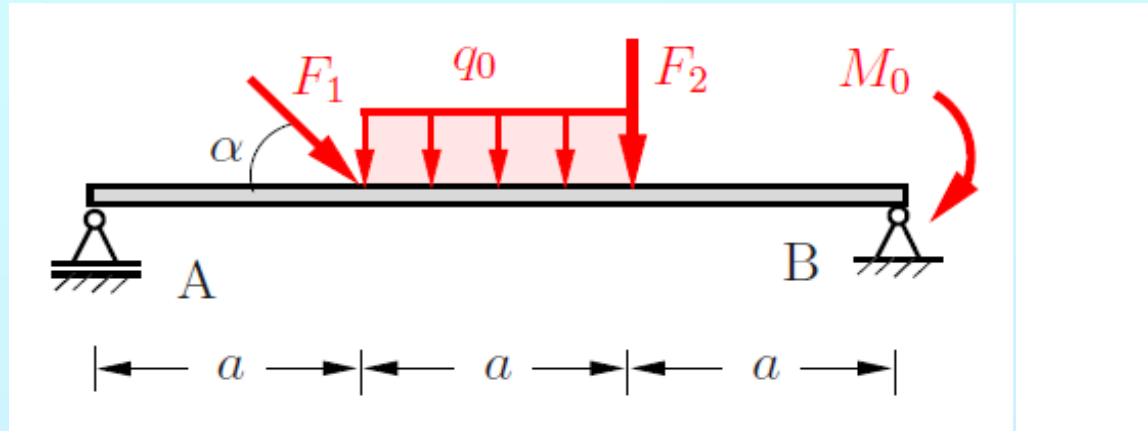

## 2. Spatial Structures

A body that can move freely in space has six degrees of freedom  $f=6$ :  
3 translations in  $x$ ,  $y$  &  $z$  direction and 3 rotations about the three axes.

Supports constrain the possible displacements. As in the plane case, different types of support are classified by the number of transferable support reactions.

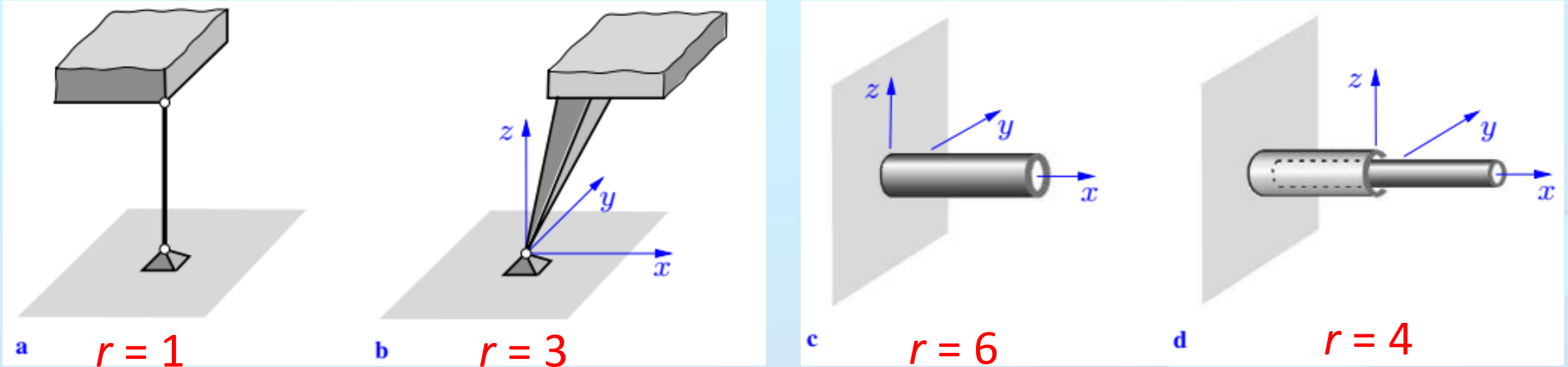



# 3. Multi-Part Structures

## 3.1. Statical Determinacy

Structures often consist not only of one single part but of a number of rigid bodies that are appropriately connected. **The connecting members transfer forces and moments, respectively, which can be made visible by passing cuts through the connections.** In the following the discussion is restricted to plane structures.

$$r + c = 3n$$

$r$  عدد ردود أفعال المساند

$c$  عدد قوى الوصل

$n$  عدد الشرائح الموصولة

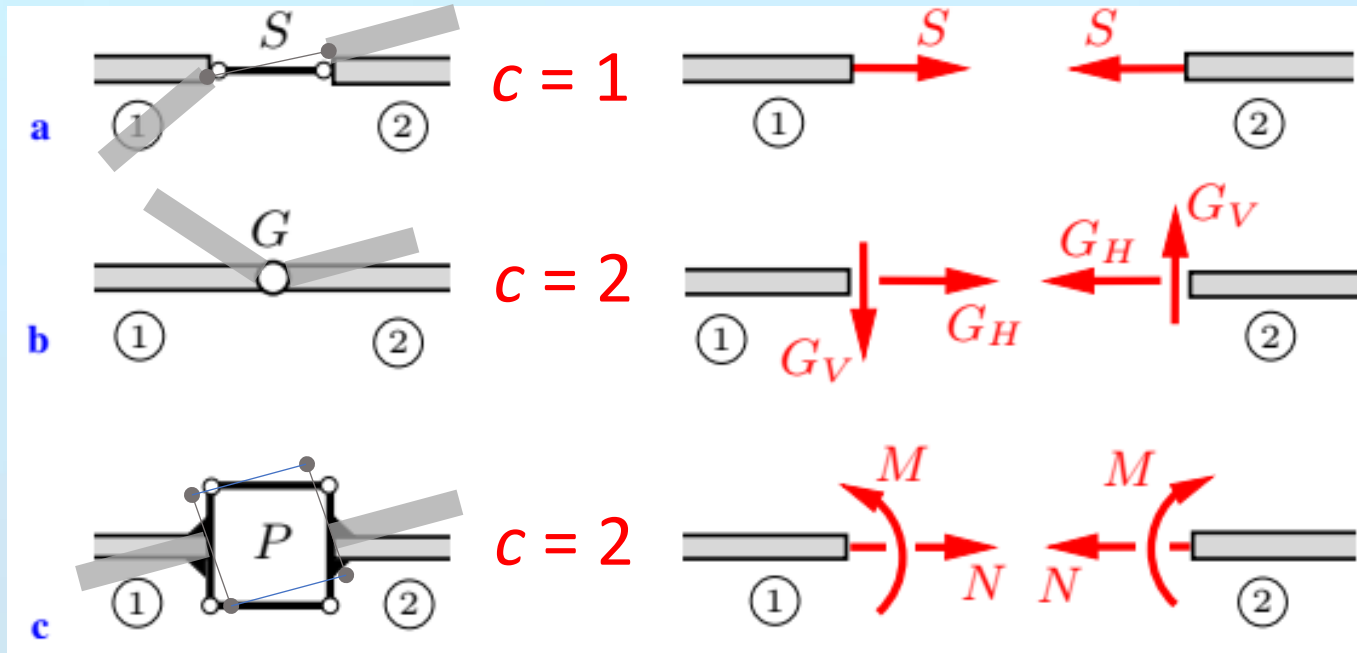

Strut

مربط

Hinge

مفصل

Parallel motion

مربط توازي

# Problem 1. Determine the support reactions for the depicted systems

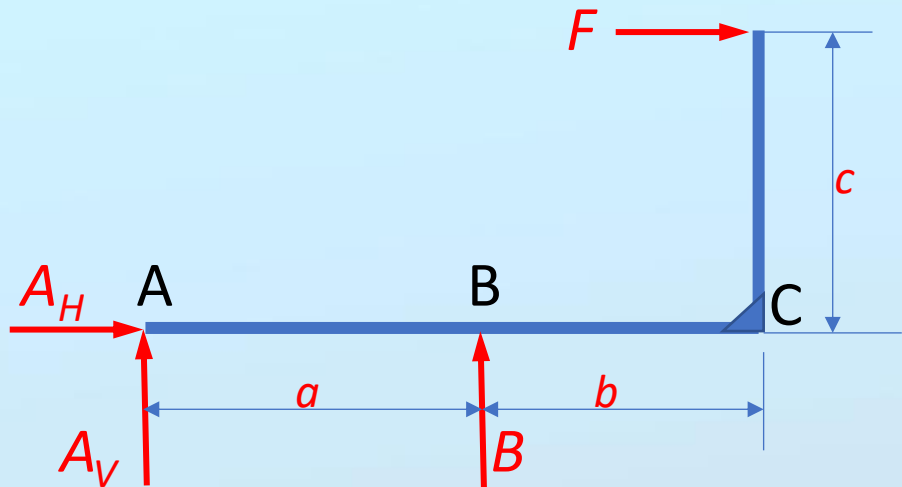
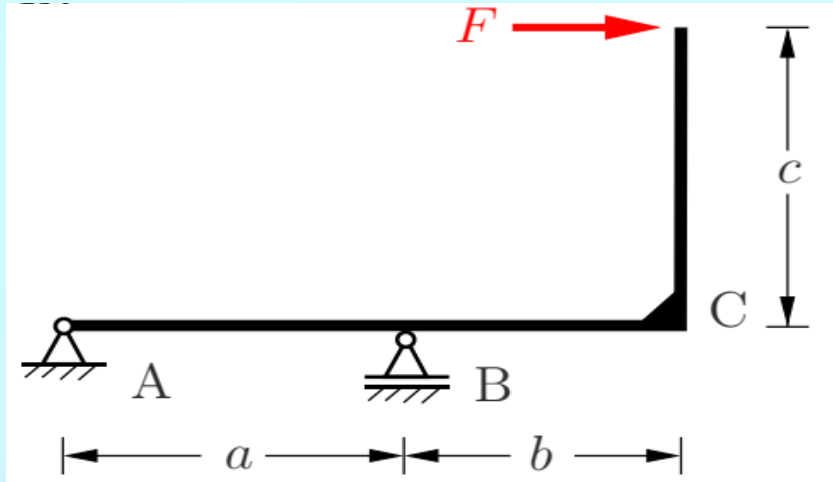

## Problem 2. Determine the support reactions for the depicted systems

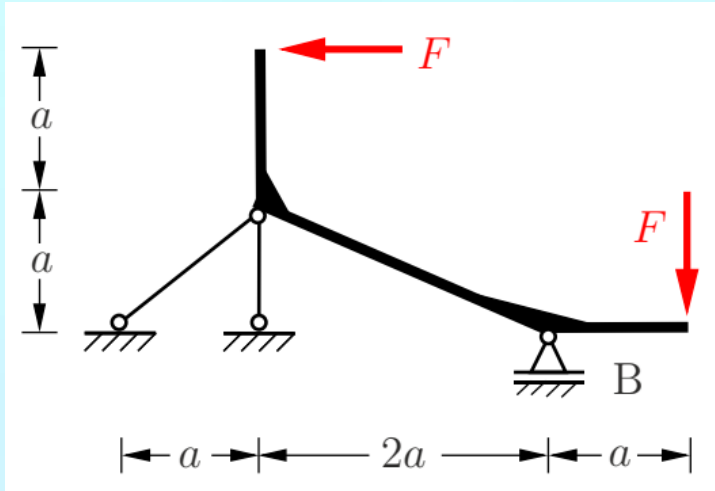

## Problem 2.

Determine the support reactions for the depicted frame.

Given:  $F_1 = 2000 \text{ N}$ ,  $F_2 = 3000 \text{ N}$ ,  $\alpha = 45^\circ$ ,  $a = 5 \text{ m}$ .

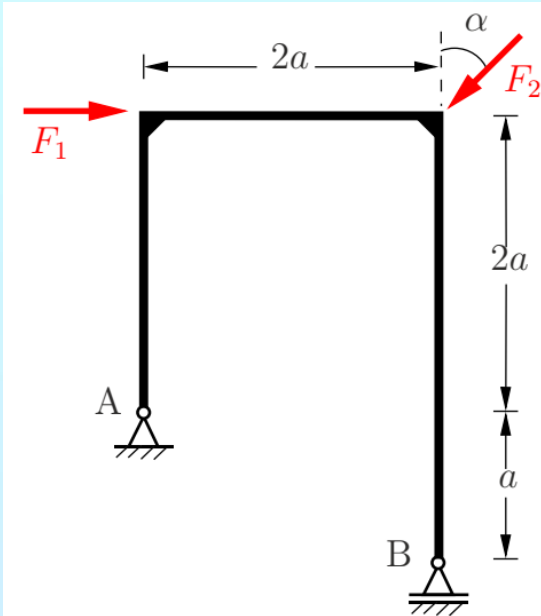

1. Draw the free Body Diagram of the shown Element
2. Find the reactions of the supports

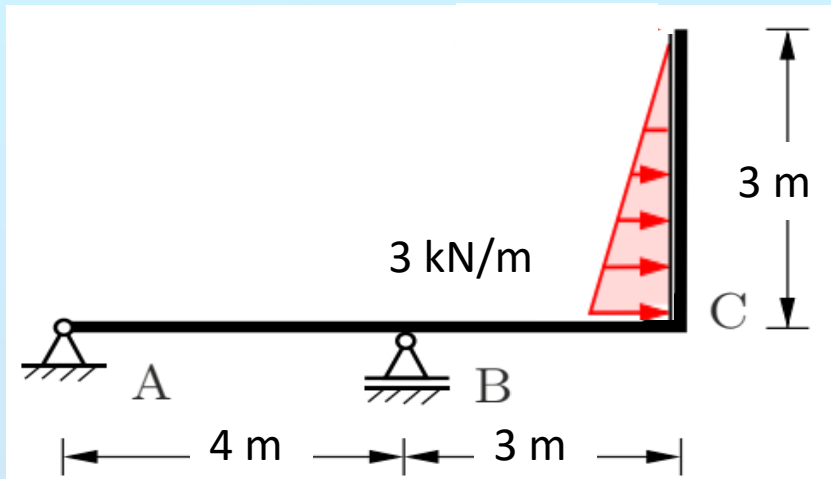
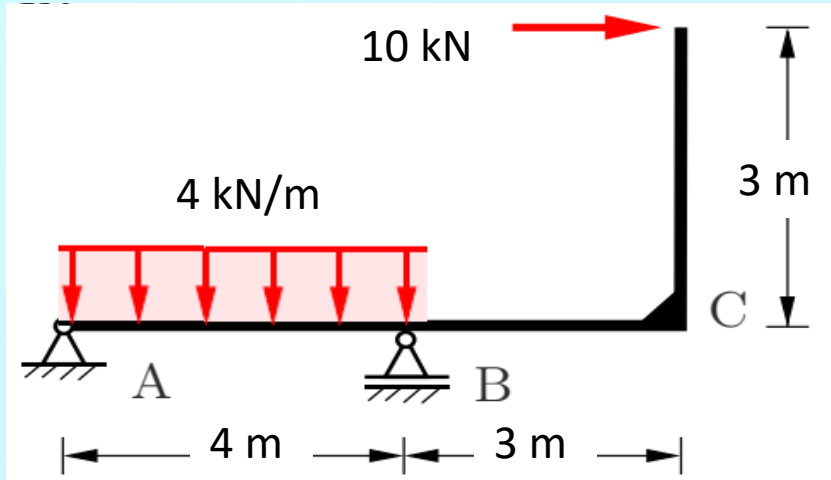

## Problem 2.

Determine the support reactions for the depicted frame.

Given:  $F_1 = 3 \text{ kN}$ ,  $F_2 = 5 \text{ kN}$ ,  $\alpha = 40^\circ$ ,  $a = 3 \text{ m}$ .

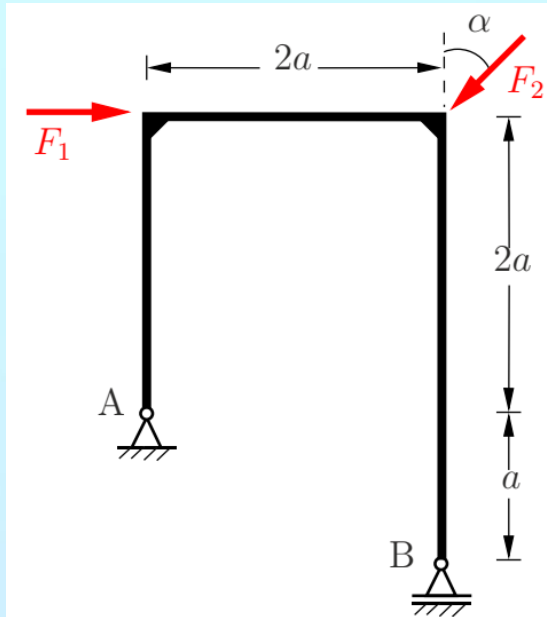

## Problem 2.

Determine the support reactions for the depicted frame.

Given:  $F_1 = 3 \text{ kN}$ ,  $F_2 = 5 \text{ kN}$ ,  $\alpha = 30^\circ$ ,  $a = 3 \text{ m}$ .

