

CECC507: Signals and Systems

Lecture Notes 5: Fourier Analysis for Continuous Time Signals and Systems

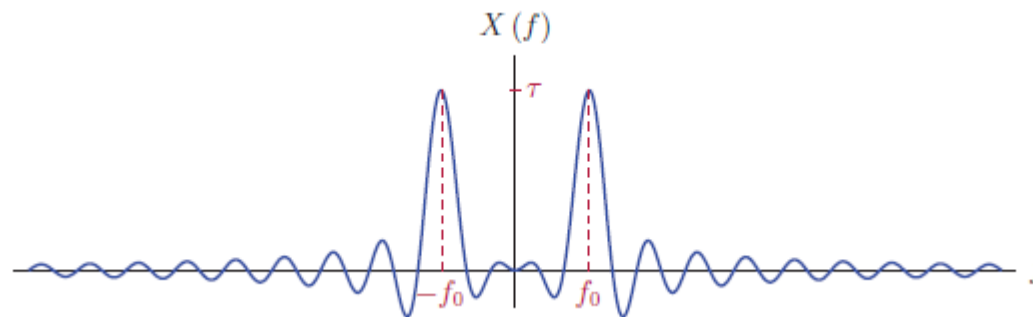

Ramez Koudsieh, Ph.D.

Faculty of Engineering
Department of Mechatronics
Manara University

Chapter 4

Fourier Analysis for Continuous Time Signals and Systems

1. Introduction
2. Analysis of Periodic Continuous-Time Signals
3. Analysis of Non-Periodic Continuous-Time Signals
4. Energy and Power in the Frequency Domain
5. Transfer Function Concept
6. CTLTI Systems with Periodic Input Signals
7. CTLTI Systems with Non-Periodic Input Signals

1. Introduction

- **Fourier analysis** leads to the **frequency spectrum** of a continuous-time signal.
- The frequency spectrum displays the various sinusoidal components that make up the signal.
- In the frequency domain linear systems are described by linear **algebraic equations** that can be easily solved, in contrast to the time-domain representation, where they are described by linear **differential equations**.
- A weighted summation of **Sines** and **Cosines** of different frequencies can be used to represent periodic (**Fourier Series**), or non-periodic (**Fourier Transform**) functions.

2. Analysis of Periodic Continuous-Time Signals

- We will study methods of expressing **periodic continuous-time signals** in two different but equivalent formats, namely the **trigonometric Fourier series (TFS)** and the **exponential Fourier series (EFS)**.

Approximating a periodic signal with trigonometric functions

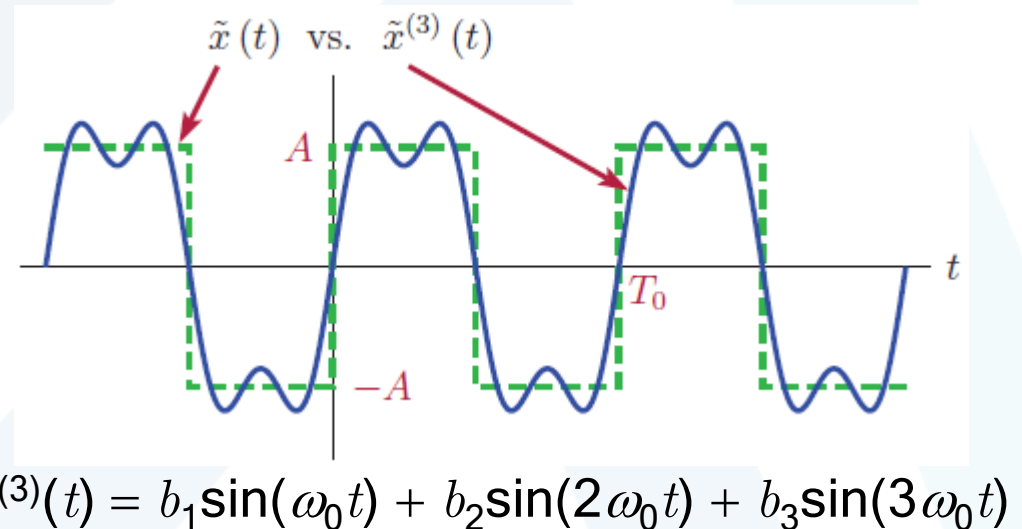
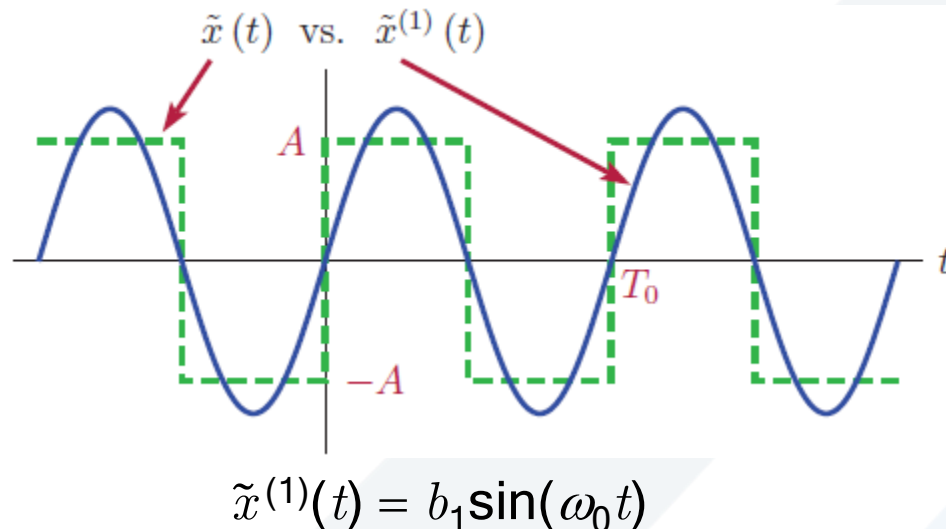

Trigonometric Fourier series (TFS)

$$\tilde{x}(t) = a_0 + a_1 \cos(\omega_0 t) + a_2 \cos(2\omega_0 t) + \dots + a_k \cos(k\omega_0 t) + \dots \\ + b_1 \sin(\omega_0 t) + b_2 \sin(2\omega_0 t) + \dots + b_k \sin(k\omega_0 t) + \dots$$

- In a compact notation (**trigonometric Fourier Series TFS** of the periodic signal $\tilde{x}(t)$):

$$\tilde{x}(t) = a_0 + \sum_{k=1}^{\infty} a_k \cos(k\omega_0 t) + \sum_{k=1}^{\infty} b_k \sin(k\omega_0 t)$$

where $\omega_0 = 2\pi f_0$ is the **fundamental frequency** in rad/s.

- We call the frequencies that are integer multiples of the fundamental frequency the **harmonics**.
- The frequencies $2\omega_0$, $3\omega_0$, ..., $k\omega_0$ are the second, the third, and the k -th harmonics of the fundamental frequency respectively.

Trigonometric Fourier series (TFS)

1. Synthesis equation:

$$\tilde{x}(t) = a_0 + \sum_{k=1}^{\infty} a_k \cos(k\omega_0 t) + \sum_{k=1}^{\infty} b_k \sin(k\omega_0 t)$$

2. Analysis equation:

$$a_0 = \frac{1}{T_0} \int_{t_0}^{t_0+T_0} \tilde{x}(t) dt \quad (\text{dc component})$$

$$a_k = \frac{2}{T_0} \int_{t_0}^{t_0+T_0} \tilde{x}(t) \cos(k\omega_0 t) dt, \quad \text{for } k = 1, 2, \dots, \infty$$

$$b_k = \frac{2}{T_0} \int_{t_0}^{t_0+T_0} \tilde{x}(t) \sin(k\omega_0 t) dt, \quad \text{for } k = 1, 2, \dots, \infty$$

- **Example 1:** Trigonometric Fourier series of a periodic pulse train

$$a_0 = \frac{1}{3} \int_0^1 (1) dt = \frac{1}{3}$$

$$a_k = \frac{2}{3} \int_0^1 (1) \cos\left(\frac{2\pi kt}{3}\right) dt = \frac{\sin(2\pi k/3)}{\pi k}, \text{ for } k = 1, 2, \dots, \infty$$

$$b_k = \frac{2}{3} \int_0^1 (1) \sin\left(\frac{2\pi kt}{3}\right) dt = \frac{1 - \cos(2\pi k/3)}{\pi k}, \text{ for } k = 1, 2, \dots, \infty$$

$$\tilde{x}(t) = \frac{1}{3} + \sum_{k=1}^{\infty} \frac{\sin(2\pi k/3)}{\pi k} \cos\left(\frac{2\pi kt}{3}\right) + \sum_{k=1}^{\infty} \frac{1 - \cos(2\pi k/3)}{\pi k} \sin\left(\frac{2\pi kt}{3}\right)$$

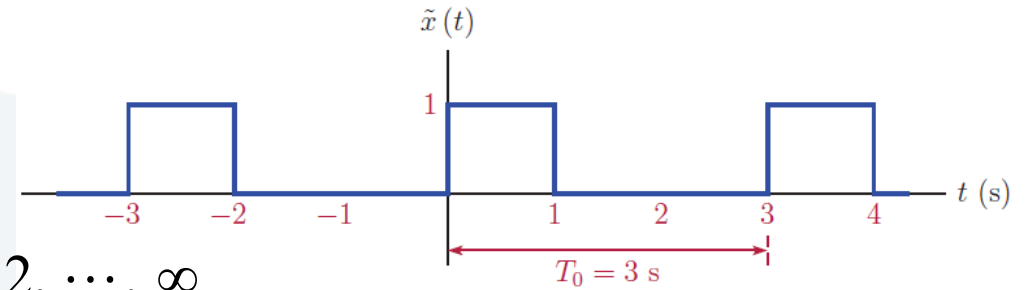

- **Example 2:** Periodic pulse train

$$\tilde{x}(t) = \frac{1}{3} + \sum_{k=1}^{\infty} \frac{2\sin(\pi k/3)}{\pi k} \cos\left(\frac{2\pi kt}{3}\right)$$

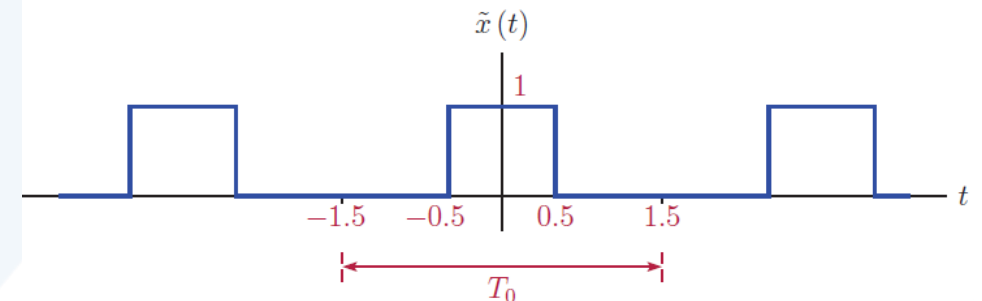

Exponential Fourier series (EFS)

$$\tilde{x}(t) = \sum_{k=-\infty}^{\infty} c_k e^{jk\omega_0 t}$$

Single-tone signals:

$$\tilde{x}(t) = A \cos(\omega_0 t + \theta) = \frac{A}{2} e^{j(\omega_0 t + \theta)} + \frac{A}{2} e^{-j(\omega_0 t + \theta)} = \frac{A}{2} e^{j\theta} e^{j\omega_0 t} + \frac{A}{2} e^{-j\theta} e^{-j\omega_0 t}$$

$$c_1 = \frac{A}{2} e^{j\theta}, \quad c_{-1} = \frac{A}{2} e^{-j\theta}, \quad \text{and} \quad c_k = 0 \text{ for all other } k$$

$$\tilde{x}(t) = A \sin(\omega_0 t + \theta) = \frac{A}{2} e^{j(\theta - \pi/2)} e^{j\omega_0 t} + \frac{A}{2} e^{-j(\theta - \pi/2)} e^{-j\omega_0 t}$$

$$c_1 = \frac{A}{2} e^{j(\theta - \pi/2)}, \quad c_{-1} = \frac{A}{2} e^{-j(\theta - \pi/2)}, \quad \text{and} \quad c_k = 0 \text{ for all other } k$$

- The EFS representations of the two signals are shown graphically, in the form of a **line spectrum**.

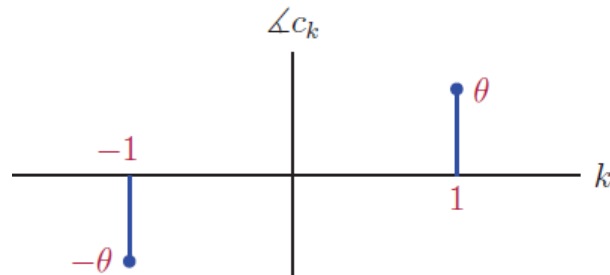
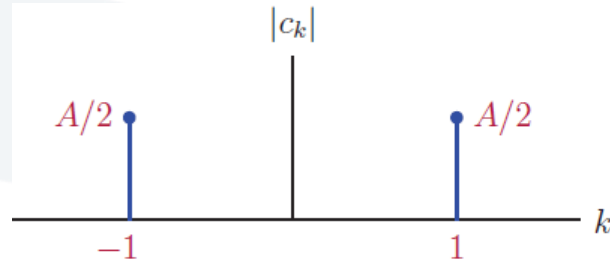

$$\tilde{x}(t) = A \cos(\omega_0 t + \theta)$$

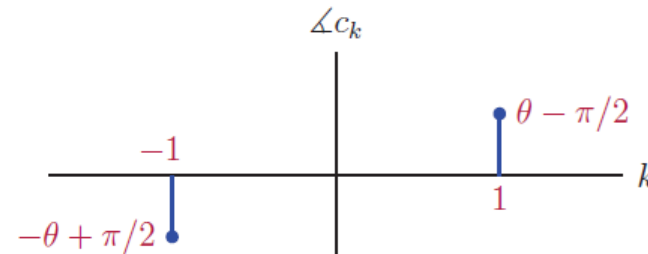
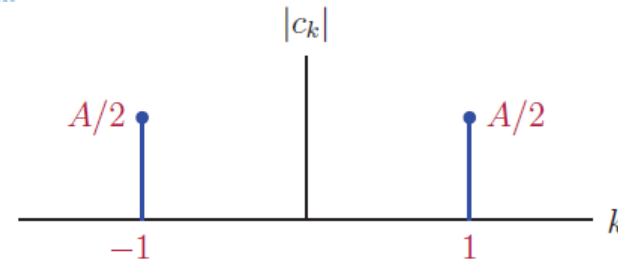

$$\tilde{x}(t) = A \sin(\omega_0 t + \theta)$$

The general case: $\tilde{x}(t) = \sum_{k=-\infty}^{\infty} c_k e^{jk\omega_0 t} = a_0 + \sum_{k=1}^{\infty} a_k \cos(k\omega_0 t) + \sum_{k=1}^{\infty} b_k \sin(k\omega_0 t)$

$$c_0 = a_0$$

$$c_k + c_{-k} = a_k \quad \text{and} \quad j(c_k - c_{-k}) = b_k, \quad \text{for } k = 1, \dots, \infty$$

$$c_k = \frac{1}{2}(a_k - jb_k) \quad \text{and} \quad c_{-k} = \frac{1}{2}(a_k + jb_k), \quad \text{for } k = 1, \dots, \infty$$

Exponential Fourier series (EFS):

1. Synthesis equation:
$$\tilde{x}(t) = \sum_{k=-\infty}^{\infty} c_k e^{jk\omega_0 t}$$

2. Analysis equation:
$$c_k = \frac{1}{T_0} \int_{t_0}^{t_0+T_0} \tilde{x}(t) e^{-jk\omega_0 t} dt$$

- In general, the coefficients of the EFS representation of a periodic signal $\tilde{x}(t)$ are **complex valued**. They can be graphed in the form of a **line spectrum** if each coefficient is expressed in polar complex form: $c_k = |c_k| e^{j\theta_k}$

- Example 3:** EFS for periodic pulse train

$$c_k = \frac{1}{3} \int_{-0.5}^{0.5} (1) e^{-j2\pi kt/3} dt = \frac{\sin(\pi k/3)}{\pi k}$$

$$\tilde{x}(t) = \sum_{k=-\infty}^{\infty} \frac{\sin(\pi k/3)}{\pi k} e^{j2\pi kt/3}$$

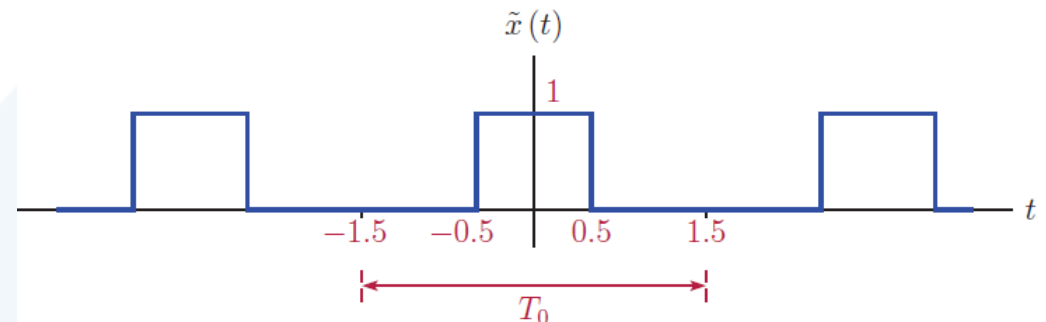

- A line graph of the set of coefficients c_k is useful for illustrating the make-up of the signal $\tilde{x}(t)$ in terms of its harmonics.

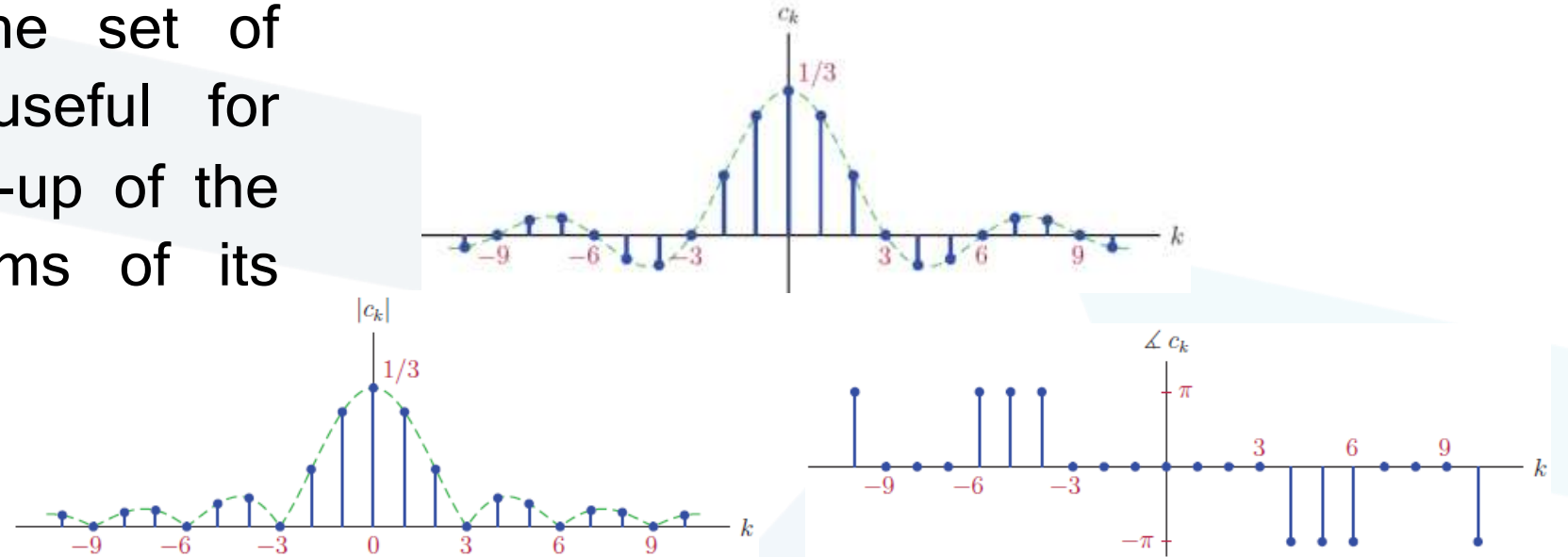

Properties of Fourier series

Linearity $\alpha_1 \tilde{x}(t) + \alpha_2 \tilde{y}(t) = \sum_{k=-\infty}^{\infty} [\alpha_1 c_k + \alpha_2 d_k] e^{jk\omega_0 t}$

Symmetry of Fourier series

$$\tilde{x}(t): \text{real, } \text{Im}\{\tilde{x}(t)\} = 0 \Rightarrow c_{-k} = c_k^*, \quad \tilde{x}(t): \text{imag, } \text{Re}\{\tilde{x}(t)\} = 0 \Rightarrow c_{-k} = -c_k^*$$

3. Analysis of Non-Periodic Continuous-Time Signals

- Consider the non-periodic signal $x(t)$.

Fourier transform for continuous-time signals:

1. Synthesis equation: (Inverse transform)

$$x(t) = \mathcal{F}^{-1}\{X(\omega)\} = \frac{1}{2\pi} \int_{-\infty}^{\infty} X(\omega) e^{j\omega t} d\omega$$

$$x(t) = \mathcal{F}^{-1}\{X(f)\} = \int_{-\infty}^{\infty} X(f) e^{j2\pi ft} df \quad (\text{using } f)$$

2. Analysis equation: (Forward transform)

$$X(\omega) = \mathcal{F}\{x(t)\} = \int_{-\infty}^{\infty} x(t) e^{-j\omega t} dt$$

$$X(f) = \mathcal{F}\{x(t)\} = \int_{-\infty}^{\infty} x(t) e^{-j2\pi ft} dt \quad (\text{using } f)$$

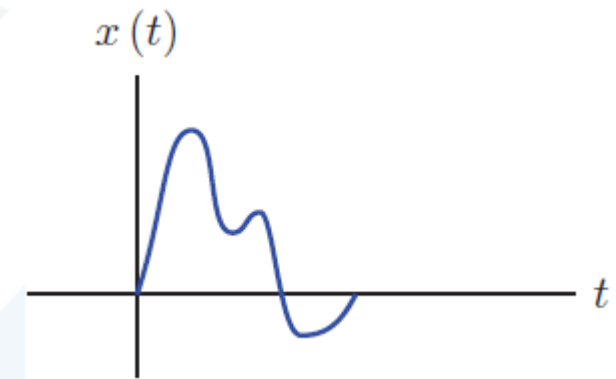

What frequencies are contained in this signal?

Fourier transforms of some signals

Example 4: Fourier transform of a rectangular pulse

$$x(t) = A\Pi\left(\frac{t}{\tau}\right)$$

$$X(\omega) = \int_{-\tau/2}^{\tau/2} (A) e^{-j\omega t} dt = A \frac{e^{-j\omega t}}{-j\omega} \Big|_{-\tau/2}^{\tau/2} = \frac{2A}{\omega} \sin\left(\frac{\omega\tau}{2}\right)$$

$$X(\omega) = A\tau \frac{\sin(\omega\tau/2)}{(\omega\tau/2)} = A\tau \operatorname{sinc}\left(\frac{\omega\tau}{2\pi}\right)$$

$$X(f) = A\tau \operatorname{sinc}(f\tau)$$

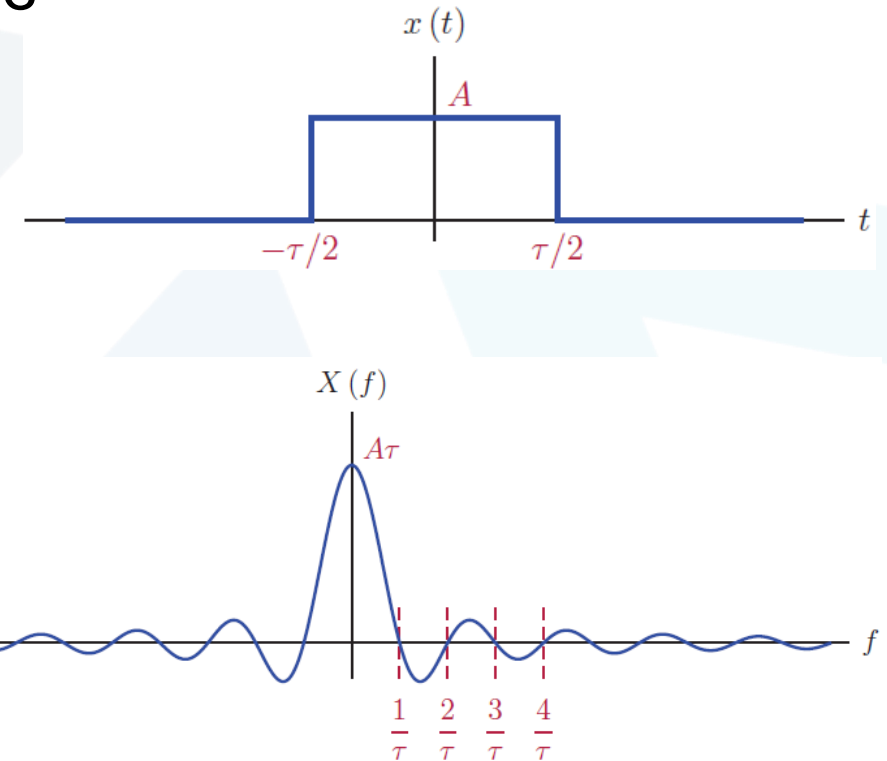

- Effects of changing the pulse width on the frequency spectrum:

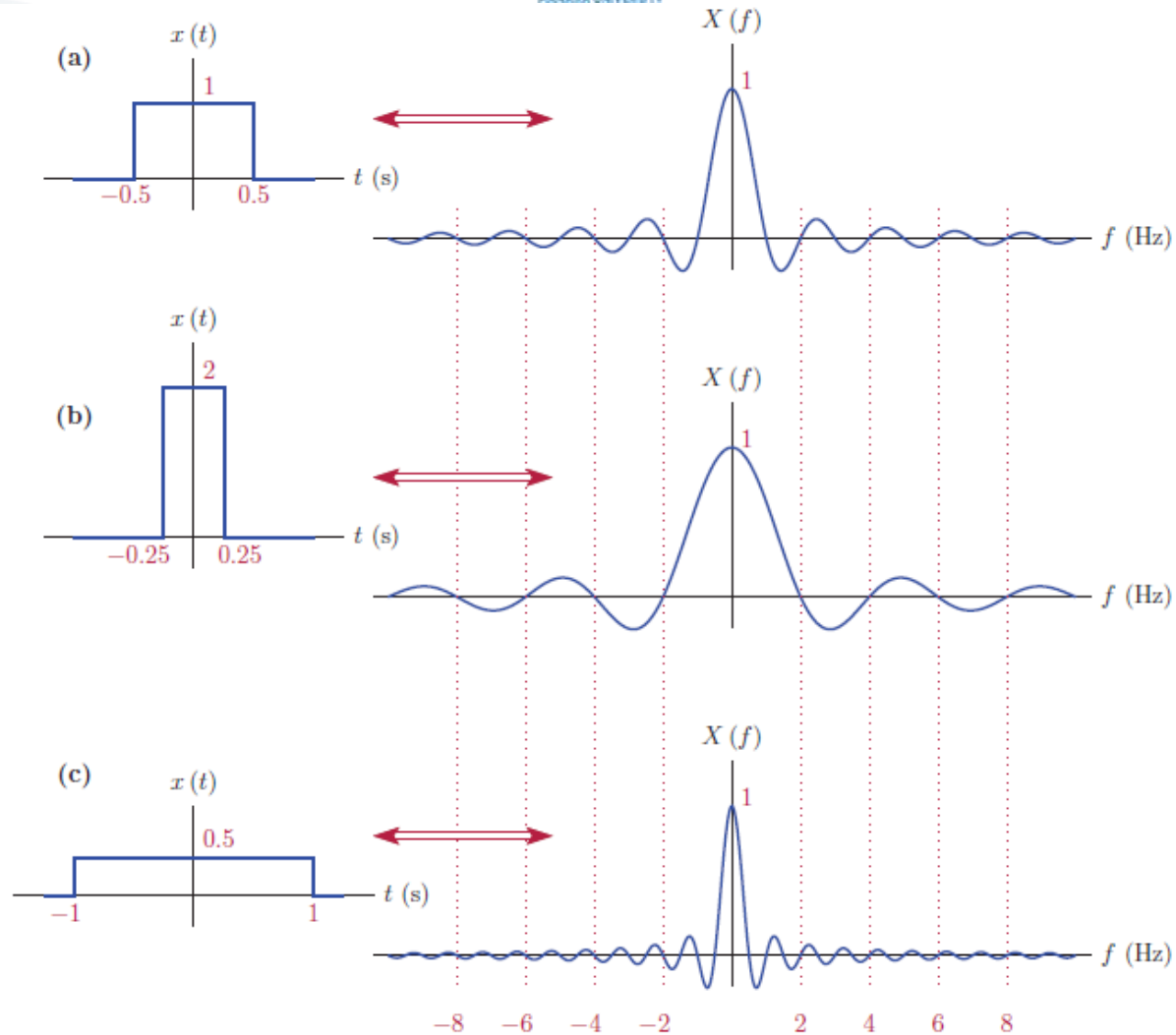

Example 5: Transform of the unit-impulse function

$$F\{\delta(t)\} = \int_{-\infty}^{\infty} \delta(t) e^{-j\omega t} dt = \int_{-\infty}^{\infty} \delta(t) dt = 1$$

Example 6: FT of a right-sided exponential signal $x(t) = e^{-at}u(t)$, $a > 0$

$$X(\omega) = \int_{-\infty}^{\infty} e^{-at} u(t) e^{-j\omega t} dt = \int_0^{\infty} e^{-at} e^{-j\omega t} dt = \frac{1}{a + j\omega}$$

$$|X(\omega)| = \left| \frac{1}{a + j\omega} \right| = \frac{1}{\sqrt{a^2 + \omega^2}}, \quad \theta(\omega) = -\tan^{-1}(\omega/a)$$

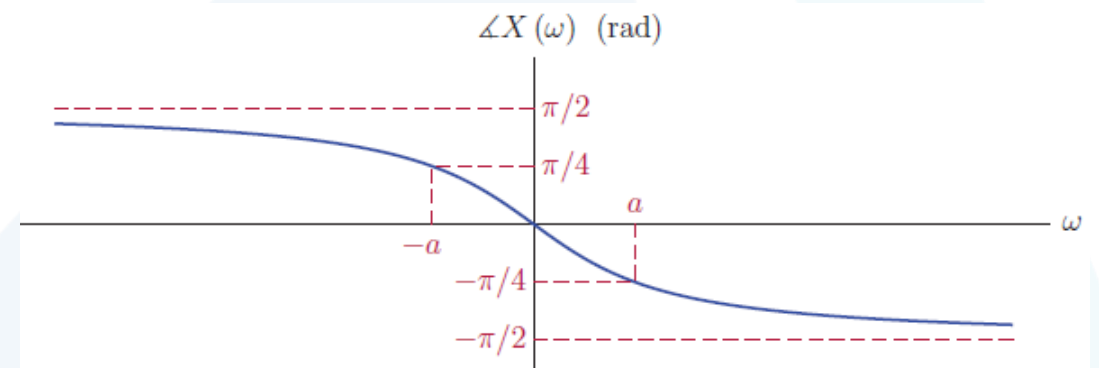
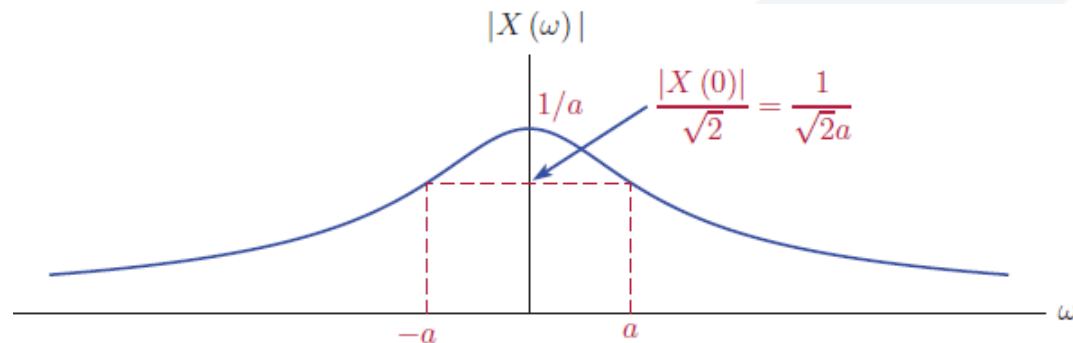
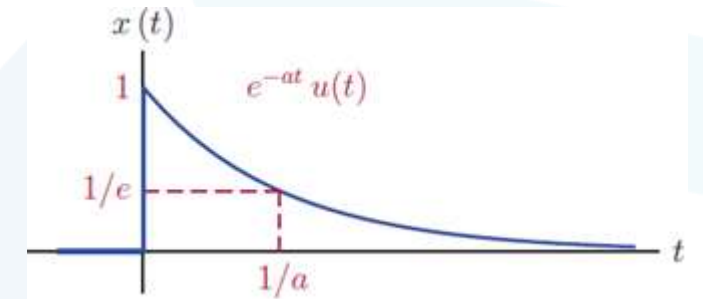

- **Example 7:** Fourier transform of a two-sided exponential signal

$$x(t) = e^{-a|t|}, \quad a > 0$$

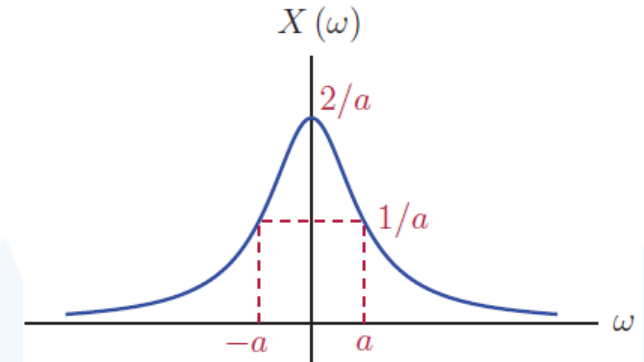
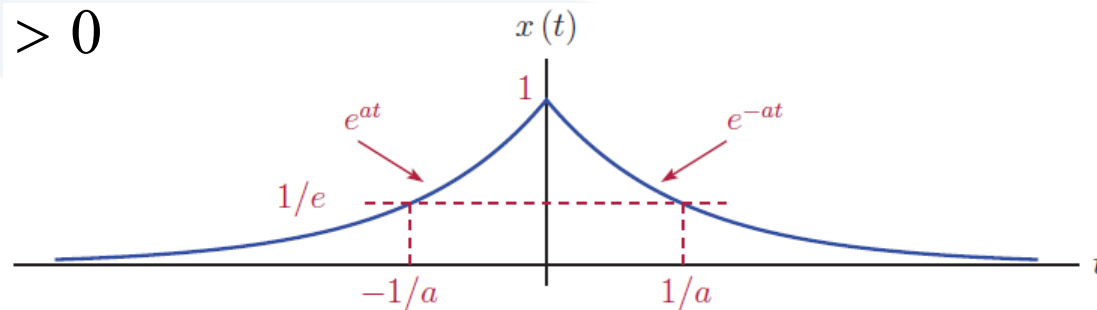

$$X(\omega) = \int_{-\infty}^{\infty} e^{-a|t|} e^{-j\omega t} dt = \int_{-\infty}^0 e^{at} e^{-j\omega t} dt + \int_0^{\infty} e^{-at} e^{-j\omega t} dt = \frac{2a}{a^2 + \omega^2}$$

- **Example 8:** Fourier transform of the signum function

$$x(t) = \text{sgn}(t) = \begin{cases} -1, & t < 0 \\ 1, & t > 0 \end{cases}$$

$$X(\omega) = \int_{-\infty}^0 (-1) e^{-j\omega t} dt + \int_0^{\infty} (1) e^{-j\omega t} dt$$

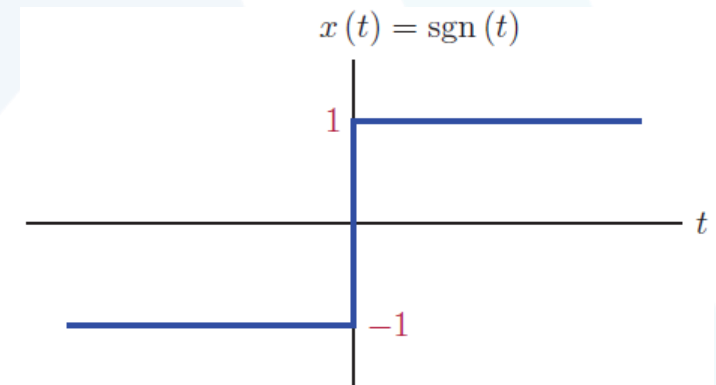

The two integrals cannot be evaluated. Instead, we will define an intermediate signal $p(t)$ as:

$$p(t) = \begin{cases} -e^{at}, & t < 0 \\ e^{-at}, & t > 0 \end{cases}, \text{ where } a \geq 0$$

$$P(\omega) = \int_{-\infty}^0 (-e^{at}) e^{-j\omega t} dt + \int_0^{\infty} (e^{-at}) e^{-j\omega t} dt = \frac{-j2\omega}{a^2 + \omega^2}$$

$$X(\omega) = \mathcal{F}\{\text{sgn}(t)\} = \lim_{a \rightarrow 0} \frac{-j2\omega}{a^2 + \omega^2} = \frac{2}{j\omega}$$

$$|X(\omega)| = \frac{2}{|\omega|}$$

$$\theta(\omega) = \begin{cases} \frac{\pi}{2}, & \omega < 0 \\ -\frac{\pi}{2}, & \omega > 0 \end{cases}$$

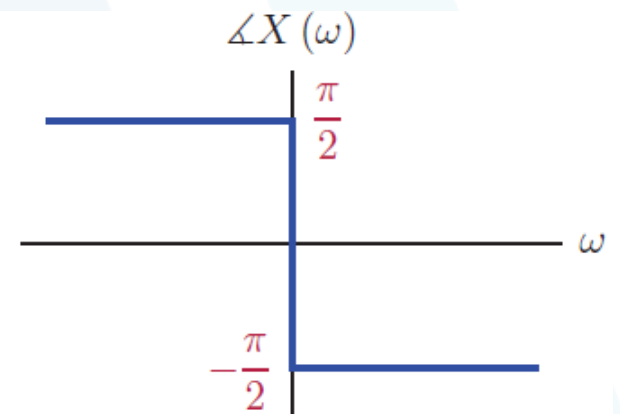
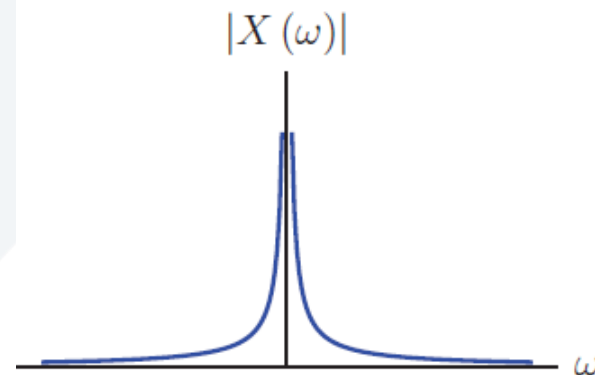
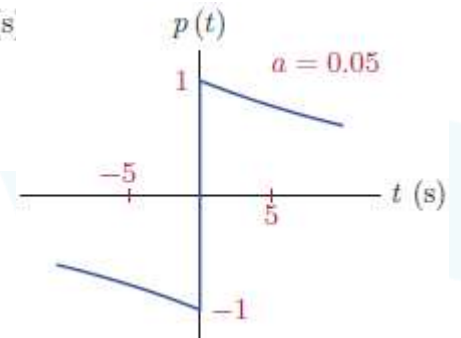
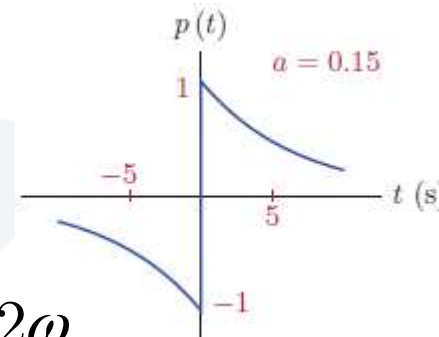

■ **Example 9:** Fourier transform of a triangular pulse

$$x(t) = A\Lambda\left(\frac{t}{\tau}\right) = \begin{cases} A + At/\tau, & -\tau < t < 0 \\ A - At/\tau, & 0 < t < \tau \\ 0, & |t| \geq \tau \end{cases}$$

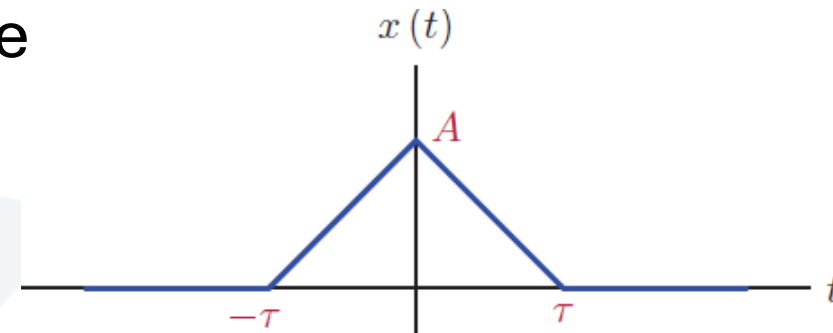

$$X(\omega) = \int_{-\tau}^0 (A + At/\tau) e^{-j\omega t} dt + \int_0^{\tau} (A - At/\tau) e^{-j\omega t} dt = \frac{2A}{\omega^2 \tau} [1 - \cos(\omega\tau)]$$

$$\text{sinc}\left(\frac{\omega\tau}{2\pi}\right) = \frac{\sin(\omega\tau/2)}{\omega\tau/2} = \frac{2}{\omega\tau} \sin\left(\frac{\omega\tau}{2}\right)$$

$$X(\omega) = A\tau \text{sinc}^2\left(\frac{\omega\tau}{2\pi}\right)$$

$$X(f) = A\tau \text{sinc}^2(f\tau)$$

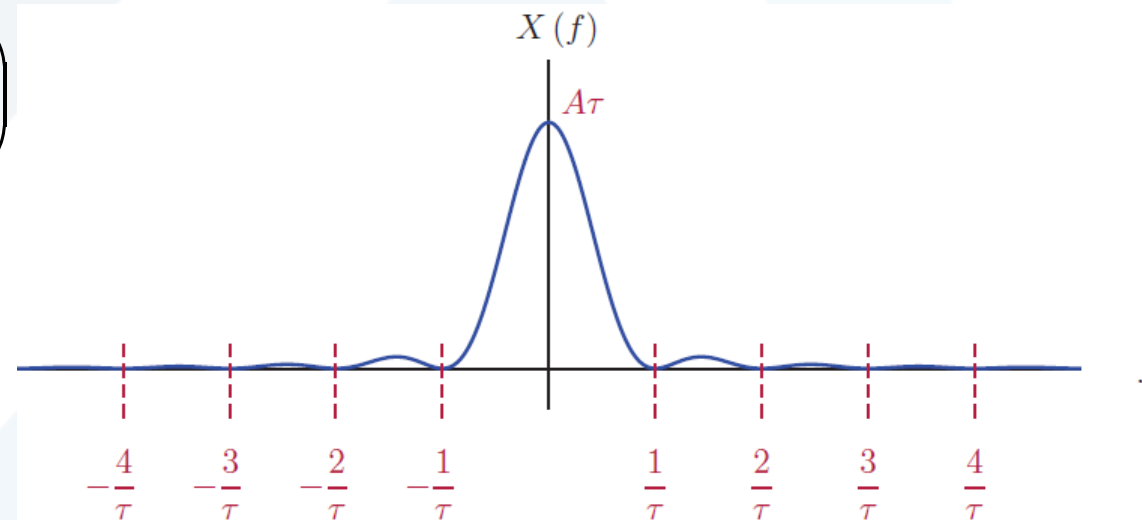

Properties of Fourier transform

Linearity of the Fourier transform: $\mathcal{F}\{\alpha_1 x(t) + \alpha_2 y(t)\} = \alpha_1 \mathcal{F}\{x(t)\} + \alpha_2 \mathcal{F}\{y(t)\}$

Duality property: $x(t) \xleftrightarrow{\mathcal{F}} X(\omega) \Rightarrow X(t) \xleftrightarrow{\mathcal{F}} 2\pi x(-\omega)$

Duality property (using f): $x(t) \xleftrightarrow{\mathcal{F}} X(f) \Rightarrow X(t) \xleftrightarrow{\mathcal{F}} x(-f)$

- **Example 10:** Fourier transform of the sinc function

$$\mathcal{F}\left\{\frac{1}{2\pi} \Pi\left(\frac{t}{2\pi}\right)\right\} = \text{sinc}(\omega) \Rightarrow$$

$$\mathcal{F}\{\text{sinc}(t)\} = \Pi\left(\frac{-\omega}{2\pi}\right) = \Pi\left(\frac{\omega}{2\pi}\right)$$

$$\mathcal{F}\{\text{sinc}(t)\} = \Pi(f)$$

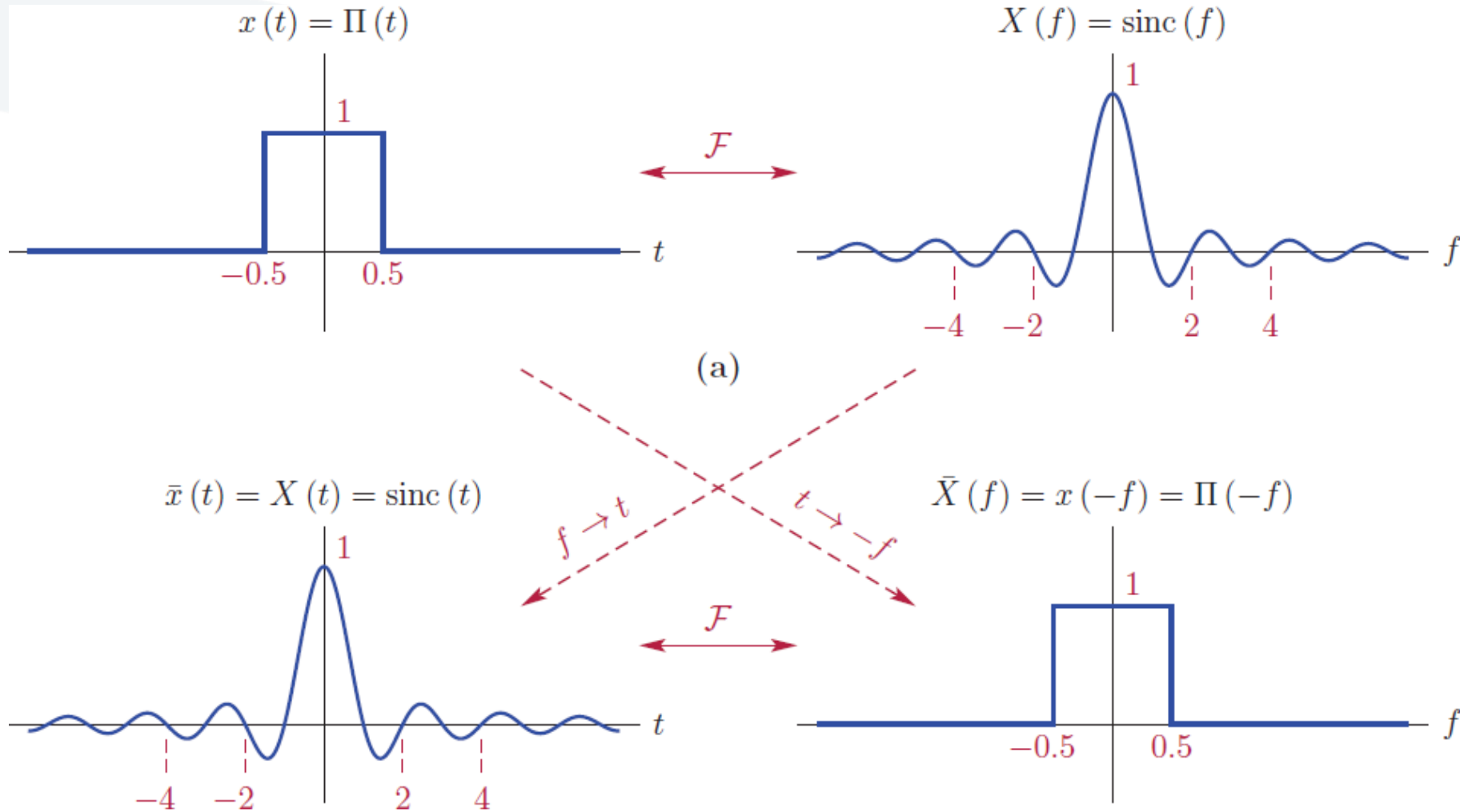

- **Example 11:** Transform of a constant-amplitude signal

$$F\{\delta(t)\} = 1, \text{ all } \omega \quad \Rightarrow \quad F\{1\} = 2\pi\delta(-\omega) = 2\pi\delta(\omega), \quad F\{1\} = \delta(f) \quad (\text{duality})$$

- **Example 12:** Fourier transform of the unit-step function

$$X(\omega) = \int_{-\infty}^{\infty} x(t) e^{-j\omega t} dt = \int_0^{\infty} e^{-j\omega t} dt \quad \text{could not be evaluated}$$

$$u(t) = \frac{1}{2} + \frac{1}{2} \text{sgn}(t)$$

$$F\{u(t)\} = F\{\frac{1}{2} + \frac{1}{2} \text{sgn}(t)\}$$

$$= \frac{1}{2}F\{1\} + \frac{1}{2}F\{\text{sgn}(t)\}$$

$$F\{u(t)\} = \pi \delta(\omega) + \frac{1}{j\omega}$$

$$F\{u(t)\} = \frac{1}{2} \delta(f) + \frac{1}{j2\pi f}$$

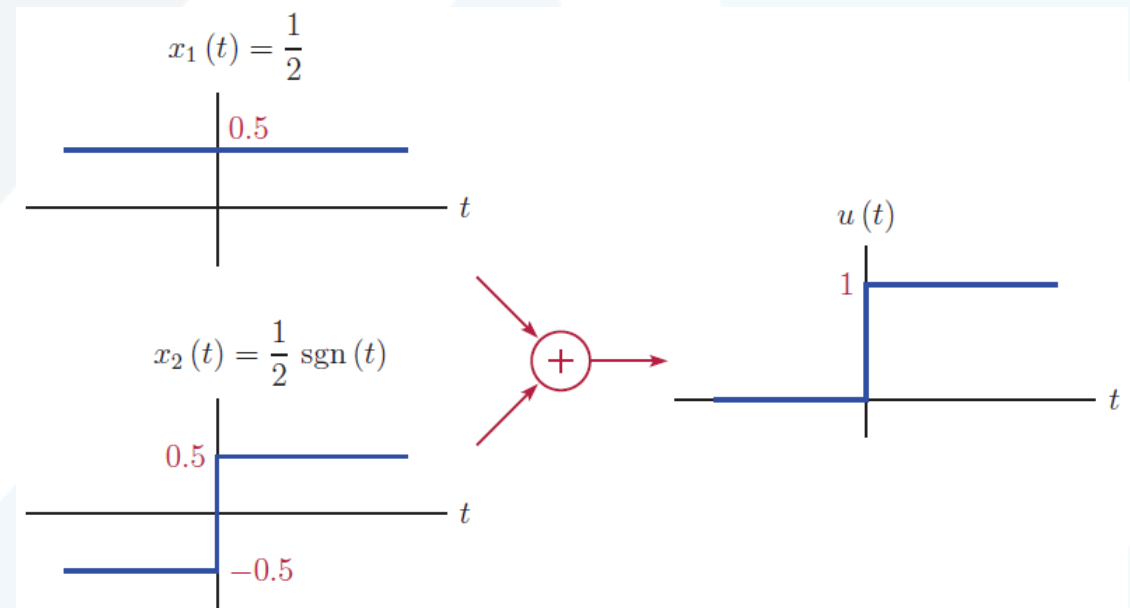

Symmetry of the Fourier transform

$$x(t): \text{real, } \text{Im}\{x(t)\} = 0 \Rightarrow X^*(\omega) = X(-\omega)$$

$$\tilde{x}(t): \text{imag, } \text{Re}\{\tilde{x}(t)\} = 0 \Rightarrow X^*(\omega) = -X(-\omega)$$

Transforms of even and odd signals

- If the real-valued signal $x(t)$ is an even function of time, the resulting Fourier transform $X(\omega)$ is real-valued for all ω .

$$x(-t) = x(t), \text{ for all } t \Rightarrow \text{Im}\{X(\omega)\} = 0, \text{ for all } \omega$$

- If the real-valued signal $x(t)$ has odd-symmetry, the resulting Fourier transform $X(\omega)$ is purely imaginary.

$$x(-t) = -x(t), \text{ for all } t \Rightarrow \text{Re}\{X(\omega)\} = 0, \text{ for all } \omega$$

Time shifting $x(t) \xleftrightarrow{\mathcal{F}} X(\omega) \Rightarrow x(t - \tau) \xleftrightarrow{\mathcal{F}} X(\omega) e^{-j\omega\tau}$

Frequency shifting $x(t) \xleftrightarrow{\mathcal{F}} X(\omega) \Rightarrow x(t) e^{j\omega_0 t} \xleftrightarrow{\mathcal{F}} X(\omega - \omega_0)$

Modulation property $x(t) \xleftrightarrow{\mathcal{F}} X(\omega) \Rightarrow$

$$x(t) \cos(\omega_0 t) \xleftrightarrow{\mathcal{F}} \frac{1}{2} [X(\omega - \omega_0) + X(\omega + \omega_0)]$$

$$x(t) \sin(\omega_0 t) \xleftrightarrow{\mathcal{F}} \frac{1}{2} [X(\omega - \omega_0) e^{-j\pi/2} + X(\omega + \omega_0) e^{j\pi/2}]$$

- **Example 13:** Modulated pulse

$$x(t) = \begin{cases} \cos(2\pi f_0 t), & |t| < \tau \\ 0, & |t| > \tau \end{cases}$$

Using $p(t)$, the signal $x(t)$ can be expressed as $x(t) = p(t) \cos(2\pi f_0 t)$

where $p(t) = \Pi\left(\frac{t}{2\tau}\right)$

$$P(f) = 2\tau \operatorname{sinc}(2\tau f)$$

$$X(f) = \frac{1}{2}[P(f - f_0) + P(f + f_0)]$$

$$= \tau \operatorname{sinc}(2\tau(f + f_0)) + \tau \operatorname{sinc}(2\tau(f - f_0))$$

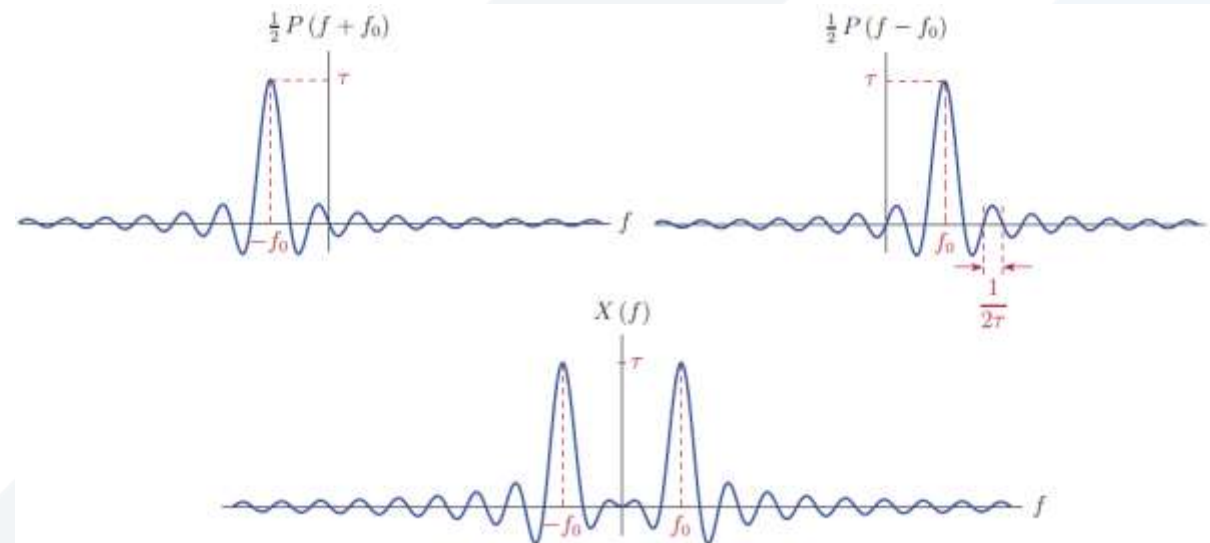
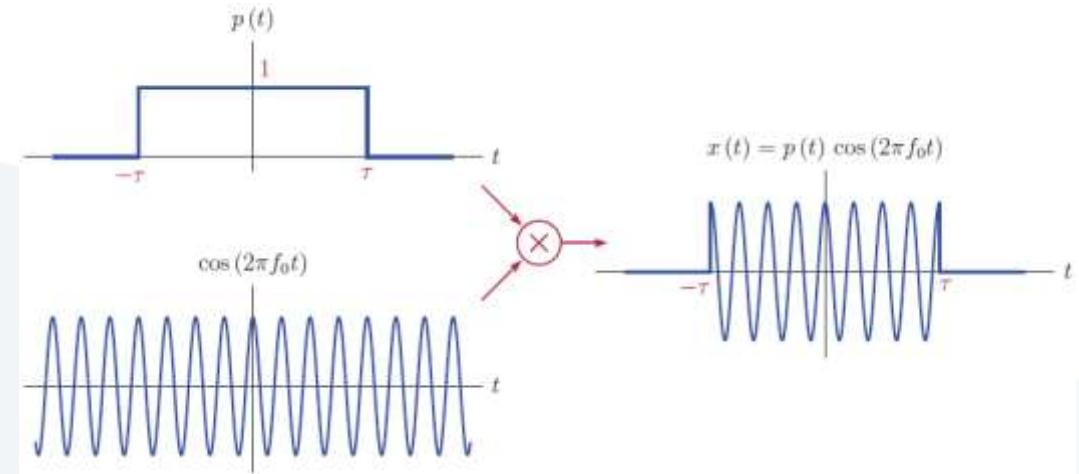

Time and frequency scaling

$$x(t) \xleftrightarrow{\mathcal{F}} X(\omega) \Rightarrow x(at) \xleftrightarrow{\mathcal{F}} \frac{1}{|a|} X\left(\frac{\omega}{a}\right)$$

The parameter a is any non-zero and real-valued constant.

Differentiation in the time domain

$$x(t) \xleftrightarrow{\mathcal{F}} X(\omega) \Rightarrow \frac{d^n}{dt^n} [x(t)] \xleftrightarrow{\mathcal{F}} (j\omega)^n X(\omega), \quad \frac{d^n}{dt^n} [x(t)] \xleftrightarrow{\mathcal{F}} (j2\pi f)^n X(f)$$

- **Example 14:** Triangular pulse revisited

$$x(t) = A\Lambda(t/\tau)$$

$$w(t) = \frac{dx(t)}{dt} = \frac{A}{\tau} \left[\Pi\left(\frac{t + \tau/2}{\tau}\right) - \Pi\left(\frac{t - \tau/2}{\tau}\right) \right]$$

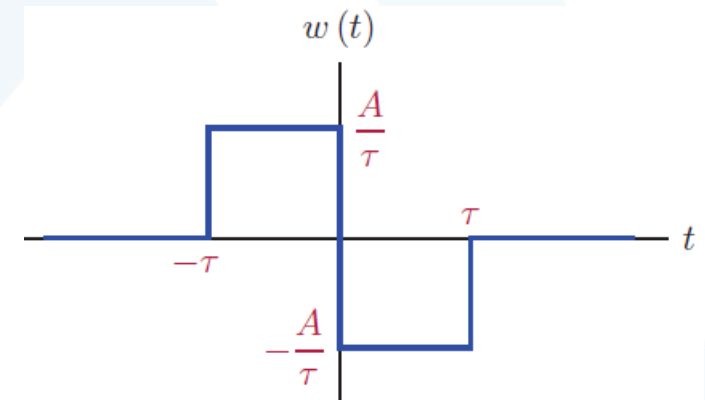

$$W(f) = A \operatorname{sinc}(f\tau) e^{j2\pi f(\tau/2)} - A \operatorname{sinc}(f\tau) e^{-j2\pi f(\tau/2)} = 2jA \operatorname{sinc}(f\tau) \sin(\pi f\tau)$$

$$W(f) = (j2\pi f)X(f) \Rightarrow X(f) = \frac{W(f)}{j2\pi f} = \frac{2jA \operatorname{sinc}(f\tau) \sin(\pi f\tau)}{j2\pi f} = A\tau \operatorname{sinc}^2(f\tau)$$

Differentiation in the frequency domain

$$x(t) \xleftrightarrow{\mathcal{F}} X(\omega) \Rightarrow (-jt)^n x(t) \xleftrightarrow{\mathcal{F}} \frac{d^n}{d\omega^n} [X(\omega)]$$

Convolution property $x_1(t) \xleftrightarrow{\mathcal{F}} X_1(\omega)$ and $x_2(t) \xleftrightarrow{\mathcal{F}} X_2(\omega)$

$$\Rightarrow x_1(t) * x_2(t) \xleftrightarrow{\mathcal{F}} X_1(\omega) X_2(\omega)$$

Multiplication of two signals $x_1(t) \xleftrightarrow{\mathcal{F}} X_1(\omega)$ and $x_2(t) \xleftrightarrow{\mathcal{F}} X_2(\omega)$

$$\Rightarrow x_1(t)x_2(t) \xleftrightarrow{\mathcal{F}} \frac{1}{2\pi} X_1(\omega) * X_2(\omega), \quad x_1(t)x_2(t) \xleftrightarrow{\mathcal{F}} X_1(f) * X_2(f)$$

Integration $x(t) \xleftrightarrow{\mathcal{F}} X(\omega) \Rightarrow \int_{-\infty}^t x(\tau) d\tau \xleftrightarrow{\mathcal{F}} \frac{X(\omega)}{j\omega} + \pi X(0)\delta(\omega)$

Applying Fourier transform to periodic signals

- **Example 15:** Fourier transform of complex exponential signal

$$x(t) = e^{j\omega_0 t}$$

$$\mathcal{F}\{1\} = 2\pi\delta(\omega) \Rightarrow \mathcal{F}\{e^{j\omega_0 t}\} = 2\pi\delta(\omega - \omega_0)$$

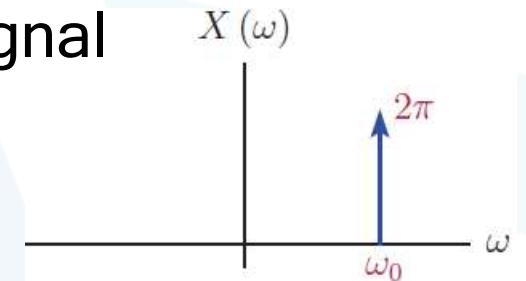

- **Example 16:** Fourier transform of sinusoidal signal

$$x(t) = \cos(\omega_0 t)$$

$$\mathcal{F}\{1\} = 2\pi\delta(\omega) \Rightarrow \mathcal{F}\{\cos(\omega_0 t)\} = \pi\delta(\omega - \omega_0) + \pi\delta(\omega + \omega_0)$$

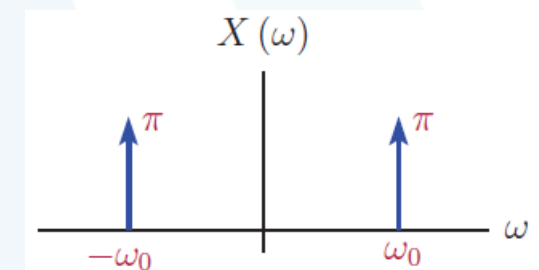

- The idea can be generalized to apply to any periodic continuous-time signal that has an EFS representation:

$$\tilde{x}(t) = \sum_{k=-\infty}^{\infty} c_k e^{jk\omega_0 t} \Rightarrow X(\omega) = \int_{-\infty}^{\infty} \tilde{x}(t) e^{-j\omega t} dt = \int_{-\infty}^{\infty} \left[\sum_{k=-\infty}^{\infty} c_k e^{jk\omega_0 t} \right] e^{-j\omega t} dt$$

$$X(\omega) = \sum_{k=-\infty}^{\infty} c_k \left[\int_{-\infty}^{\infty} e^{jk\omega_0 t} e^{-j\omega t} dt \right]$$

$$= \sum_{k=-\infty}^{\infty} c_k [2\pi\delta(\omega - k\omega_0)]$$

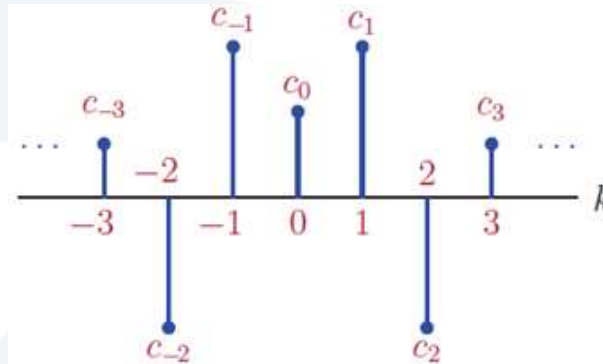

EFS coefficients for a signal

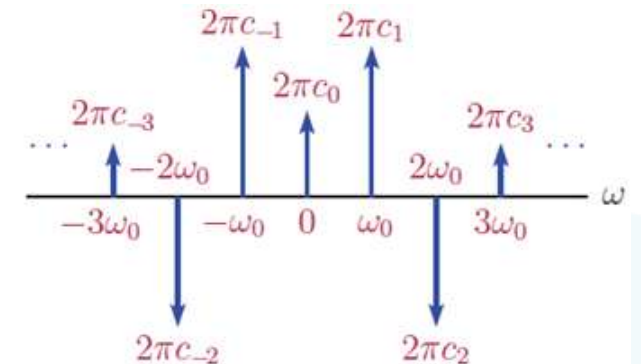

Fourier transform obtained

■ **Example 17:** Fourier transform of periodic pulse train

Determine the FT of the periodic pulse train with duty cycle $d = \tau/T_0$

$$c_k = d \text{sinc}(kd) \quad X(\omega) = \sum_{k=-\infty}^{\infty} 2\pi d \text{sinc}(kd) \delta(\omega - k\omega_0)$$

$\omega_0 = 1/T_0$ is the fundamental radian frequency.

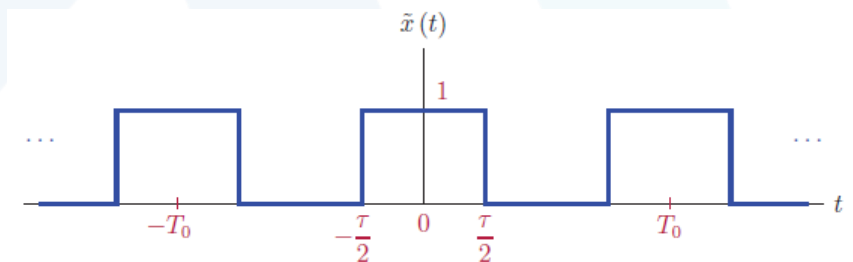

4. Energy and Power in the Frequency Domain

Parseval's theorem

- For a periodic power signal $\tilde{x}(t)$ with period T_0 and EFS coefficients $\{c_k\}$:

$$\frac{1}{T_0} \int_{t_0}^{t_0+T_0} |\tilde{x}(t)|^2 dt = \sum_{k=-\infty}^{\infty} |c_k|^2$$

- For a non-periodic energy signal $x(t)$ with a Fourier transform $X(f)$:

$$\int_{-\infty}^{\infty} |x(t)|^2 dt = \int_{-\infty}^{\infty} |X(f)|^2 df$$

Energy and power spectral density

$$S_x(f) = \sum_{k=-\infty}^{\infty} |c_k|^2 \delta(f - kf_0) \quad \text{power spectral density of the signal } x(t)$$

$$\int_{-\infty}^{\infty} S_x(f) df = \frac{1}{2\pi} \int_{-\infty}^{\infty} S_x(\omega) d\omega = \sum_{k=-\infty}^{\infty} |c_k|^2$$

$$P_x \text{ in } (-f_0, f_0) = \int_{-f_0}^{f_0} S_x(f) df$$

$$G_x(f) = |X(f)|^2 \quad \text{energy spectral density of the signal } x(t)$$

$$\int_{-\infty}^{\infty} |x(t)|^2 dt = \int_{-\infty}^{\infty} G_x(f) df = \frac{1}{2\pi} \int_{-\infty}^{\infty} G_x(\omega) d\omega$$

- **Example 18:** Power spectral density of a periodic pulse train

Determine the power spectral density for $x(t)$. Also find the total power, the dc power, the power in the first three harmonics, and the power above 1 Hz.

$$c_k = \frac{1}{3} \text{sinc}(k/3) \quad S_x(f) = \sum_{k=-\infty}^{\infty} \left| \frac{1}{3} \text{sinc}(k/3) \right|^2 \delta(f - k/3)$$

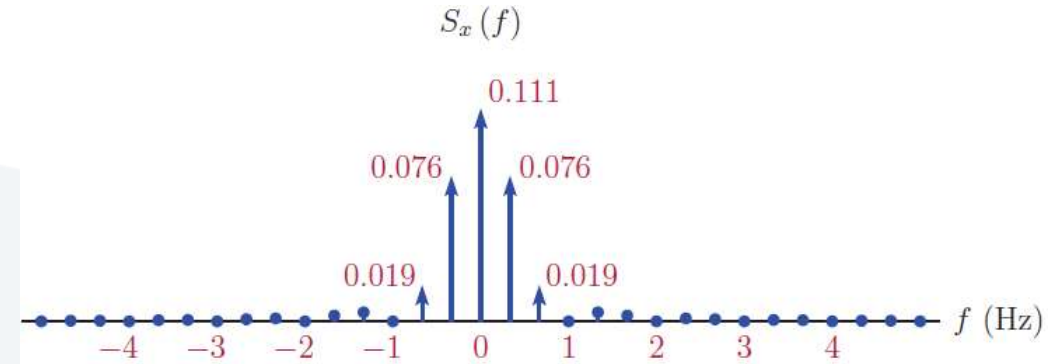
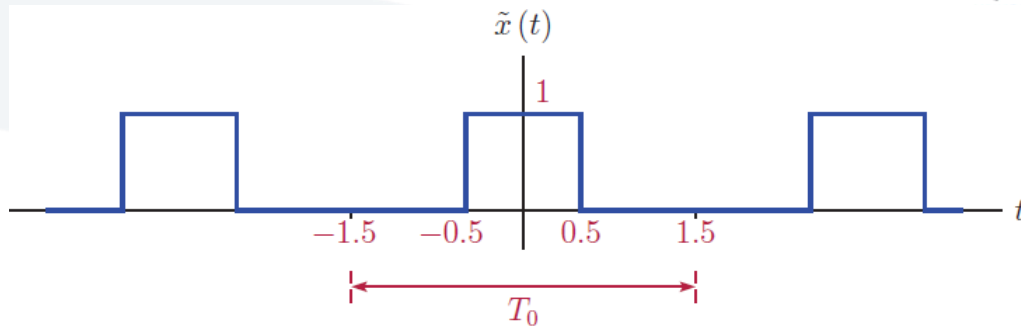

The total power in the signal $x(t)$: $\frac{1}{T_0} \int_{t_0}^{t_0+T_0} |\tilde{x}(t)|^2 dt = \frac{1}{3} \int_{-0.5}^{0.5} (1)^2 dt = \frac{1}{3}$

$$P_1 = |c_{-1}|^2 + |c_1|^2 = \frac{3}{2\pi^2} \approx 0.1520, \quad P_2 = |c_{-2}|^2 + |c_2|^2 = \frac{3}{8\pi^2} \approx 0.0380, \quad P_3 = 0$$

The third harmonic is at frequency $f = 1$ Hz. Thus, the power above 1 Hz:

$$P_{hf} = P_x - P_{dc} - P_1 - P_2 - P_3 = 0.3333 - 0.1111 - 0.1520 - 0.0380 - 0 = 0.0322$$

- Example 19:** Energy spectral density of the sinc function

Determine the energy spectral density of $x(t) = \text{sinc}(10t)$. Afterwards, compute the total energy, and the energy in the sinc pulse at frequencies up to 3 Hz.

$$X(f) = \frac{1}{10} \Pi\left(\frac{f}{10}\right), \quad G_x(f) = |X(f)|^2 = \frac{1}{100} \text{sinc}^2\left(\frac{f}{10}\right)$$

$$E_x = \int_{-\infty}^{\infty} G_x(f) df = \int_{-5}^5 \frac{1}{100} df = 0.1$$

$$E_x \text{ in } (-3, 3 \text{ Hz}) = \int_{-3}^3 G_x(f) df = \int_{-3}^3 \frac{1}{100} df = 0.06$$

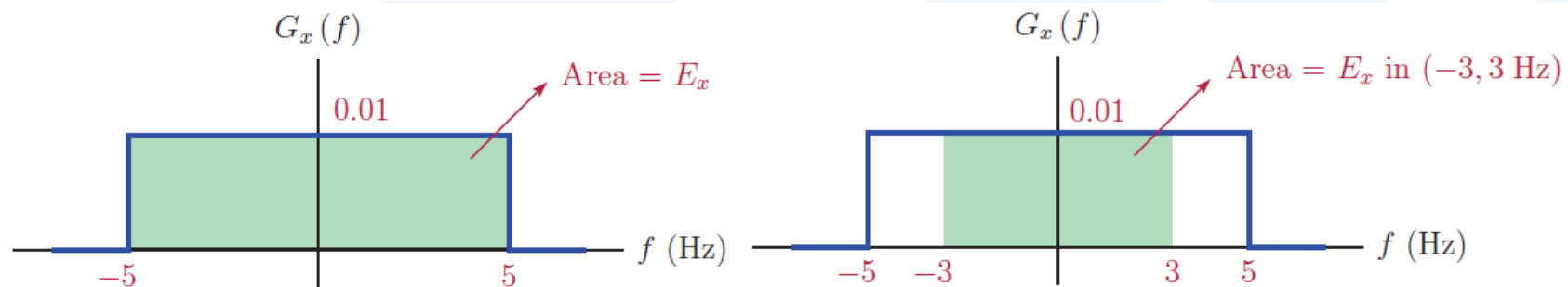
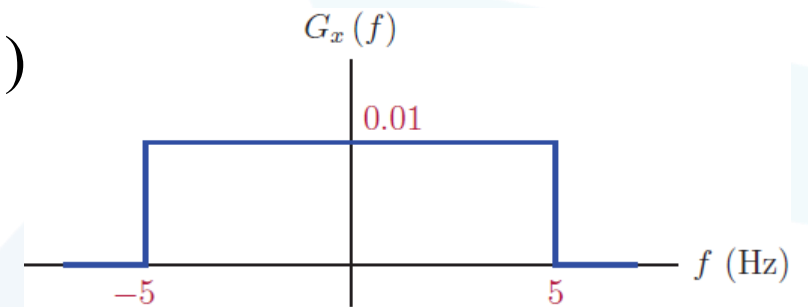

Autocorrelation

- For an energy signal $x(t)$ the **autocorrelation function** is defined as

$$r_{xx}(\tau) = \int_{-\infty}^{\infty} x(t)x(t + \tau)dt$$

- For a periodic power signal $\tilde{x}(t)$ with period T_0 , the corresponding definition of the autocorrelation function is:

$$\tilde{r}_{xx}(\tau) = \frac{1}{T_0} \int_{-T_0/2}^{T_0/2} \tilde{x}(t)\tilde{x}(t + \tau)dt$$

- The energy spectral density is the FT of the autocorrelation function:

$$F\{r_{xx}(\tau)\} = G_x(f)$$

- The power spectral density is the FT of the autocorrelation function:

$$F\{\tilde{r}_{xx}(\tau)\} = S_x(f)$$

- **Example 20:** Power spectral density of a sinusoidal signal revisited

$$\tilde{x}(t) = 5\cos(200\pi t)$$

$$\tilde{r}_{xx}(\tau) = \frac{1}{0.01} \int_{-0.005}^{0.005} 25 \cos(200\pi t) \cos(200\pi[t + \tau]) dt = \frac{25}{2} \cos(200\pi\tau)$$

$$S_x(f) = F\{\tilde{r}_{xx}(\tau)\} = \frac{25}{4} \delta(f + 100) + \frac{25}{4} \delta(f - 100)$$

Properties of the autocorrelation function

- $r_{xx}(0) \geq |r_{xx}(\tau)|$ for all τ
- $r_{xx}(-\tau) = r_{xx}(\tau)$ for all τ , that is, the autocorrelation function has even symmetry.
- If the signal $x(t)$ is periodic with period T , then its autocorrelation function $\tilde{r}_{xx}(\tau)$ is also periodic with the same period.

5. Transfer Function Concept

- In **time-domain** analysis of systems we have relied on two distinct description forms for CTLTI systems:
 1. A **linear constant-coefficient differential equation** that describes the relationship between the input and the output signals.
 2. An **impulse response** which can be used with the **convolution operation** for determining the response of the system to an arbitrary input signal.
- The concept of **Transfer function** will be introduced as the third method for describing the characteristics of a system.

$$H(\omega) = F\{h(t)\} = \int_{-\infty}^{\infty} h(t)e^{-j\omega t} dt$$

- The transfer function concept is **valid** for LTI systems only.
- In general, $H(\omega)$ is a complex function of ω , $H(\omega) = |H(\omega)|e^{j\Theta(\omega)}$.
- **Example 21:** Transfer function for the simple RC circuit

$$h(t) = \frac{1}{RC} e^{-t/RC} u(t)$$

$$H(\omega) = \int_0^{\infty} \frac{1}{RC} e^{-t/RC} e^{-j\omega t} dt = \frac{1}{1 + j\omega RC} = \frac{1}{1 + j(\omega/\omega_c)},$$

$$\omega_c = \frac{1}{RC}$$

$$|H(\omega)| = \frac{1}{\sqrt{1 + (\omega/\omega_c)^2}}, \quad \Theta(\omega) = -\tan^{-1}(\omega/\omega_c)$$

$$H(\omega_c) = \frac{1}{1 + j}, \quad |H(\omega_c)| = \frac{1}{\sqrt{2}}$$

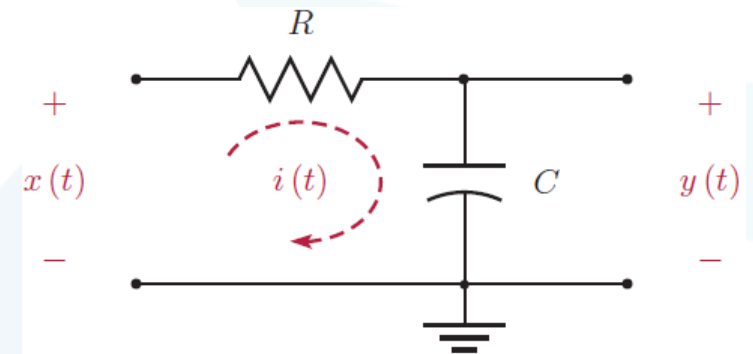

- ω_c represents the frequency at which the magnitude of the transfer function is 3 decibels below its peak value at $\omega = 0$,

$$20 \log_{10} \frac{|H(\omega_c)|}{|H(0)|} = 20 \log_{10} \frac{1}{\sqrt{2}} \approx -3\text{dB}$$
- The frequency ω_c is often referred to as the **3-dB cutoff frequency** of the system.

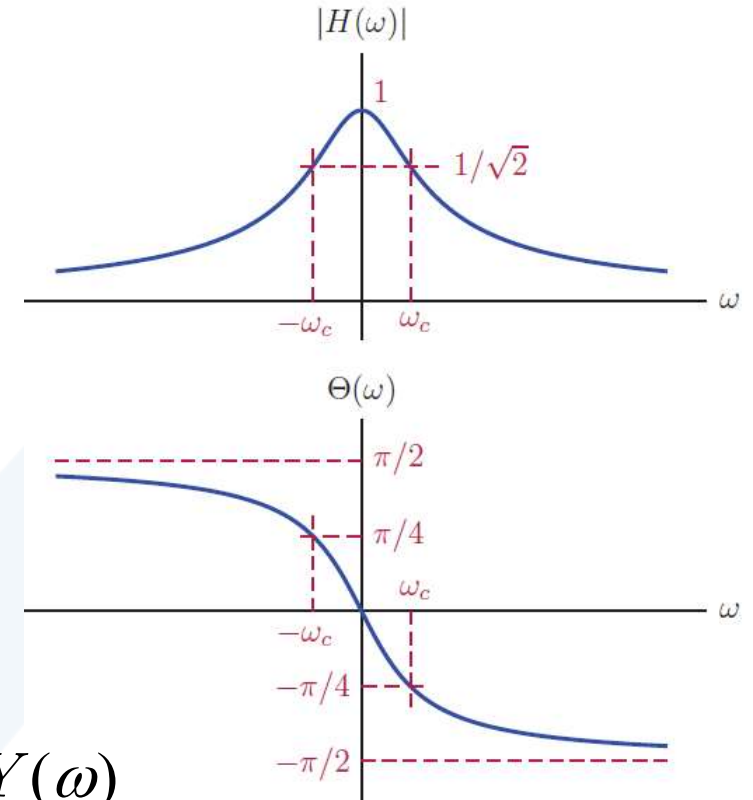

Obtaining the TF from the differential equation

$$y(t) = h(t) * x(t) \xrightarrow{\mathcal{F}} Y(\omega) = H(\omega)X(\omega) \Rightarrow H(\omega) = \frac{Y(\omega)}{X(\omega)}$$

$$\frac{d^k y(t)}{dt^k} \xrightarrow{\mathcal{F}} (j\omega)^k Y(\omega), \quad \frac{d^k x(t)}{dt^k} \xrightarrow{\mathcal{F}} (j\omega)^k X(\omega), \quad k = 0, 1, \dots$$

- **Example 22:** Transfer function from the differential equation

$$\frac{d^2y(t)}{dt^2} + 2\frac{dy(t)}{dt} + 26y(t) = x(t)$$

$$(j\omega)^2 Y(\omega) + 2(j\omega)Y(\omega) + 26Y(\omega) = X(\omega)$$

$$[(26 - \omega^2) + j2\omega] Y(\omega) = X(\omega) \Rightarrow H(\omega) = \frac{1}{(26 - \omega^2) + j2\omega}$$

6. CTLTI Systems with Periodic Input Signals

$$\tilde{x}(t) = a_0 + \sum_{k=1}^{\infty} a_k \cos(k\omega_0 t) + \sum_{k=1}^{\infty} b_k \sin(k\omega_0 t) = \sum_{k=-\infty}^{\infty} c_k e^{jk\omega_0 t}$$

Response of a CTLTI system to complex exponential signal

$$\tilde{x}(t) = e^{j\omega_0 t}$$

$$\begin{aligned}
 y(t) &= h(t) * \tilde{x}(t) = \int_{-\infty}^{\infty} h(\tau) \tilde{x}(t - \tau) d\tau = \int_{-\infty}^{\infty} h(\tau) e^{j\omega_0(t-\tau)} d\tau \\
 &= e^{j\omega_0 t} \int_{-\infty}^{\infty} h(\tau) e^{-j\omega_0 \tau} d\tau = e^{j\omega_0 t} H(\omega_0) = |H(\omega_0)| e^{j[\omega_0 t + \Theta(\omega_0)]}
 \end{aligned}$$

- That is, $e^{j\omega t}$ is an **eigenfunction** of a LTI system and $H(\omega)$ is the corresponding **eigenvalue**. We refer to H as the **frequency response** of the system.

Response of a CTLTI system to sinusoidal signal

$$\tilde{x}(t) = \cos(\omega_0 t)$$

$$\tilde{x}(t) = \cos(\omega_0 t) = \frac{1}{2} e^{j\omega_0 t} + \frac{1}{2} e^{-j\omega_0 t}$$

$$y(t) = \frac{1}{2} e^{j\omega_0 t} H(\omega_0) + \frac{1}{2} e^{-j\omega_0 t} H(-\omega_0)$$

$$= \frac{1}{2} e^{j\omega_0 t} |H(\omega_0)| e^{j\Theta(\omega_0)} + \frac{1}{2} e^{-j\omega_0 t} |H(-\omega_0)| e^{-j\Theta(\omega_0)}$$

If the impulse response $h(t)$ is real-valued:

$$|H(-\omega_0)| = |H(\omega_0)|, \quad \Theta(-\omega_0) = -\Theta(\omega_0)$$

$$y(t) = \frac{1}{2}|H(\omega_0)|e^{j[\omega_0 t + \Theta(\omega_0)]} + \frac{1}{2}|H(\omega_0)|e^{-j[\omega_0 t + \Theta(\omega_0)]} = |H(\omega_0)|\cos(\omega_0 t + \Theta(\omega_0))$$

Response of a CTLTI system to periodic input signal

$$\tilde{x}(t) = \sum_{k=-\infty}^{\infty} c_k e^{jk\omega_0 t}$$

$$T\{\tilde{x}(t)\} = T\left\{\sum_{k=-\infty}^{\infty} c_k e^{jk\omega_0 t}\right\} = \sum_{k=-\infty}^{\infty} T\{c_k e^{jk\omega_0 t}\} = \sum_{k=-\infty}^{\infty} c_k T\{e^{jk\omega_0 t}\} = \sum_{k=-\infty}^{\infty} c_k H(k\omega_0) e^{jk\omega_0 t}$$

7. CTLTI Systems with Non-Periodic Input Signals

$$y(t) = h(t) * x(t) \Rightarrow Y(\omega) = H(\omega)X(\omega)$$

$$|Y(\omega)| = |H(\omega)||X(\omega)|, \quad \angle Y(\omega) = \angle X(\omega) + \Theta(\omega)$$

■ **Example 23:** Pulse response of RC circuit

Consider again the RC circuit. Let $f_c = 1/RC = 80$ Hz. Determine the FT of the response of the system to the unit-pulse input signal $x(t) = \Pi(t)$.

$$H(f) = \frac{1}{1 + j(f/f_c)}, \quad X(f) = \text{sinc}(f),$$

$$Y(f) = \frac{1}{1 + j(f/80)} \text{sinc}(f),$$

$$|Y(f)| = \frac{1}{\sqrt{1 + (f/80)^2}} |\text{sinc}(f)|,$$

$$\angle Y(f) = -\tan^{-1}(f/80) + \angle[\text{sinc}(f)]$$

